

SPILLSTENSILER NM Veteran, 03. august 2010

♠ Q5 Mappren: **6(6)**
 ♥ 942 Runden: **2**
 ♦ AT962 ØV (Ø)
 ♣ KT5

♠ A2 T876
 ♥ AQT83 J7
 ♦ 53 QJ4
 ♣ Q742 AJ86
 ♠ KJ943
 ♥ K65
 ♦ K87
 ♣ 93

♠ 3 Mappren: **7(7)**
 ♥ J962 Runden: **2**
 ♦ KJT32 A(S)
 ♣ T84

♠ KQJ7 A4
 ♥ Q84 KT753
 ♦ 854 A7
 ♣ 732 AQJ9
 ♠ T9852
 ♥ A
 ♦ Q96
 ♣ K65

♠ 9643 Mappren: **8(8)**
 ♥ A743 Runden: **2**
 ♦ 432 I(V)
 ♣ 94

♠ 5 JT82
 ♥ KJ62 T5
 ♦ AKQ T876
 ♣ AQ763 KJ5
 ♠ AKQ7
 ♥ Q98
 ♦ J95
 ♣ T82

♠ 8 Mappren: **9(9)**
 ♥ J864 Runden: **3**
 ♦ QT62 ØV(N)
 ♣ KQT4

♠ K5432 Q9
 ♥ KQ95 32
 ♦ K A984
 ♣ A65 J9872
 ♠ AJT76
 ♥ AT7
 ♦ J753
 ♣ 3

♠ AKQJ73 Mappren: **10(10)**
 ♥ 6 Runden: **3**
 ♦ T5 A(Ø)
 ♣ A952

♠ 9542 T8
 ♥ Q852 AT3
 ♦ Q43 J9872
 ♣ J4 Q87
 ♠ 6
 ♥ KJ974
 ♦ AK6
 ♣ KT63

Bord	NS	ØV	NS	ØV	NS	ØV	Bord	NS	ØV	NS	ØV	Bord	NS	ØV	NS	ØV	Bord	NS	ØV	NS	ØV	Bord	NS	ØV	NS	ØV	Bord	NS	ØV	NS	ØV	Bord	NS	ØV	NS	ØV	Bord	NS	ØV	NS	ØV			
23	47	45	3	Hjertes	V 7	200	32,0	-32,0	6	10	12	3	NT	V 7	200	30,0	-30,0	8	14	16	3	Ruter	Ø 8	50	31,0	-31,0	15	48	38	3	Kløver	Ø 7	200	32,0	-34,0	14	57	6	6	Spar	N 12	1430	31,0	-31,0
33	67	65	1	Spar	Ø 6	100	29,0	-29,0	11	23	21	4	Hjertes	Ø 8	200	30,0	-30,0	11	23	21	5	Kløver	Ø 10	50	31,0	-31,0	6	16	12	3	Ruter	S 9	110	28,9	-30,9	17	36	25	6	Spar	N 12	1430	31,0	-31,0
30	58	60	3	Kløver	V 8	100	29,0	-29,0	34	66	68	4	Hjertes	Ø 8	200	30,0	-30,0	25	51	49	1	Spar	S 6	50	28,0	-28,0	12	61	55	3	Ruter	S 9	110	28,9	-30,9	30	8	20	3	NT	S 13	720	28,0	-28,0
31	63	61	3	Kløver	S 8	50	25,0	-25,0	18	34	36	3	NT	V 8	100	25,0	-25,0	12	22	24	1	Hjertes	V 7	80	26,0	-26,0	7	24	21	2	Spar	V 7	100	21,7	-23,7	5	19	7	3	NT	S 12	690	25,0	-25,0
24	46	48	3	Ruter	N 8	50	25,0	-25,0	15	31	29	4	Hjertes	Ø 9	100	25,0	-25,0	15	31	29	2	Spar	S 6	100	22,0	-22,0	19	45	9	2	Spar	V 7	100	21,7	-23,7	8	14	51	3	NT	S 12	690	25,0	-25,0
26	50	52	2	Spar	S 6	100	21,0	-21,0	9	17	19	3	Hjertes	Ø 10	170	21,0	-21,0	2	2	4	2	Spar	S 6	100	22,0	-22,0	10	40	4	3	Kløver	Ø 8	100	21,7	-23,7	25	41	39	4	Spar	N 12	680	15,0	-15,0
25	51	49	3	Ruter	N 7	100	21,0	-21,0	4	6	8	3	Hjertes	Ø 10	170	21,0	-21,0	31	63	61	2	Spar	N 6	100	22,0	-22,0	5	19	7	3	Kløver	Ø 8	100	21,7	-23,7	28	22	23	4	Spar	N 12	680	15,0	-15,0
3	7	5	2	Kløver	V 9	110	18,0	-18,0	24	46	48	2	NT	Ø 10	180	18,0	-18,0	29	59	57	2	Kløver	V 10	130	12,0	-12,0	1	54	43	3	Kløver	Ø 8	100	21,7	-23,7	24	50	3	4	Spar	N 12	680	15,0	-15,0
28	54	56	2	NT	Ø 8	120	16,0	-16,0	31	63	61	2	Spar	D S 7	200	16,0	-16,0	17	35	33	2	Kløver	V 10	130	12,0	-12,0	28	22	23	1	NT	N 7	90	9,3	-11,3	10	40	4	4	Spar	N 12	680	15,0	-15,0
5	11	9	2	Kløver	V 10	130	7,0	-7,0	19	39	37	1	NT	Ø 11	210	14,0	-14,0	10	18	20	2	Kløver	Ø 10	130	12,0	-12,0	4	33	27	2	Ruter	S 8	90	9,3	-11,3	2	18	66	4	Spar	N 12	680	15,0	-15,0
13	27	25	2	Kløver	V 10	130	7,0	-7,0	16	30	32	2	Spar	D S 6	500	8,0	-8,0	3	7	5	3	Kløver	Ø 10	130	12,0	-12,0	8	14	51	2	Ruter	N 8	90	9,3	-11,3	23	56	2	4	Spar	N 12	680	15,0	-15,0
18	34	36	2	Kløver	V 10	130	7,0	-7,0	12	22	24	2	Spar	D S 6	500	8,0	-8,0	22	42	44	3	Kløver	V 10	130	12,0	-12,0	24	50	3	2	Ruter	S 8	90	9,3	-11,3	26	60	29	4	Spar	N 12	680	15,0	-15,0
10	18	20	3	Kløver	V 10	130	7,0	-7,0	10	18	20	2	Spar	D S 6	500	8,0	-8,0	19	39	37	3	Kløver	V 10	130	12,0	-12,0	21	5	58	2	Ruter	S 8	90	9,3	-11,3	31	32	34	5	Spar	N 12	680	15,0	-15,0
27	55	53	3	Kløver	V 10	130	7,0	-7,0	26	50	52	2	Spar	D S 6	500	8,0	-8,0	23	47	45	3	Kløver	V 10	130	12,0	-12,0	23	56	2	2	Ruter	S 8	90	9,3	-11,3	3	64	31	3	NT	N 11	660	6,0	-6,0
2	2	4	3	Kløver	V 10	130	7,0	-7,0	20	38	40	2	Spar	D S 6	500	8,0	-8,0	20	38	40	1	Kløver	V 11	150	-1,0	1,0	25	41	39	2	Ruter	S 8	90	9,3	-11,3	6	16	12	4	Spar	N 11	650	-5,0	5,0
21	43	41	3	Kløver	V 10	130	7,0	-7,0	28	54	56	3	NT	Ø 9	600	2,0	-2,0	6	10	12	2	Kløver	V 11	150	-1,0	1,0	13	1	67	1	NT	N 6	50	-5,2	3,1	13	1	67	4	Spar	N 11	650	-5,0	5,0
22	42	44	3	Kløver	V 10	130	7,0	-7,0	33	67	65	4	Hjertes	Ø 10	620	-7,0	7,0	24	46	48	2	NT	V 9	150	-1,0	1,0	14	57	6	1	NT	N 6	50	-5,2	3,1	11	42	49	4	Spar	N 11	650	-5,0	5,0
20	38	40	2	Hjertes	V 9	140	-6,0	6,0	17	35	33	4	Hjertes	Ø 10	620	-7,0	7,0	30	58	60	2	NT	V 9	150	-1,0	1,0	3	64	31	2	Ruter	S 7	50	-5,2	3,1	1	54	43	4	Spar	N 11	650	-5,0	5,0
15	31	29	2	Hjertes	V 9	140	-6,0	6,0	2	2	4	4	Hjertes	Ø 10	620	-7,0	7,0	32	62	64	3	Kløver	V 11	150	-1,0	1,0	9	30	59	2	Spar	S 7	50	-5,2	3,1	7	24	21	4	Spar	N 11	650	-5,0	5,0
32	62	64	2	Hjertes	Ø 9	140	-6,0	6,0	3	7	5	4	Hjertes	Ø 10	620	-7,0	7,0	18	34	36	4	Kløver	V 11	150	-1,0	1,0	11	42	49	3	Ruter	S 8	50	-5,2	3,1	12	61	55	4	Spar	N 11	650	-5,0	5,0
12	22	24	2	Hjertes	V 9	140	-6,0	6,0	29	59	57	4	Hjertes	Ø 10	620	-7,0	7,0	13	27	25	2	NT	V 10	180	-8,0	8,0	2	18	66	3	Ruter	S 8	50	-5,2	3,1	4	33	27	4	Spar	N 11	650	-5,0	5,0
19	39	37	3	Hjertes	V 9	140	-6,0	6,0	30	58	60	4	Hjertes	V 10	620	-7,0	7,0	9	17	19	2	NT	V 11	210	-10,0	10,0	31	32	34	3	Ruter	S 8	50	-5,2	3,1	33	65	17	4	Spar	N 11	650	-5,0	5,0
11	23	21	1	NT	Ø 9	150	-17,0	17,0	27	55	53	4	Hjertes	Ø 10	620	-7,0	7,0	5	11	9	2	NT	V 12	240	-12,0	12,0	32	28	63	1	Spar	V 7	80	-14,4	12,4	16	10	46	4	Spar	N 11	650	-5,0	5,0
6	10	12	2	Spar	S 5	150	-17,0	17,0	8	14	16	4	Hjertes	Ø 10	620	-7,0	7,0	34	66	68	3	NT	V 9	400	-19,0	19,0	20	37	47	1	Spar	V 7	80	-14,4	12,4	22	68	62	5	Spar	N 11	650	-5,0	5,0
17	35	33	3	Kløver	V 11	150	-17,0	17,0	32	62	64	3	NT	V 10	630	-16,0	16,0	16	30	32	3	NT	V 9	400	-19,0	19,0	22	68	62	2	Kløver	Ø 8	90	-18,6	16,5	29	11	15	1	Spar	N 11	200	-16,0	16,0
8	14	16	3	Ruter	N 6	150	-17,0	17,0	14	26	28	4	Hjertes	Ø 11	650	-21,0	21,0	14	26	28	3	NT	V 9	400	-19,0	19,0	26	60	29	2	Kløver	Ø 8	90	-18,6	16,5	32	28	63	6	Kløver	N 11	100	-25,0	25,0
9	17	19	3	Ruter	N 6	150	-17,0	17,0	25	51	49	4	Hjertes	Ø 11	650	-21,0	21,0	4	6	8	5	Kløver	V 11	400	-19,0	19,0	17	36	25	1	NT	N 5	100	-23,7	21,7	15	48	38	6	Kløver	S 11	100	-25,0	25,0
1	3	1	3	Ruter	N 6	150	-17,0	17,0	1	3	1	4	Hjertes	Ø 11	650	-21,0	21,0	26	50	52	5	Kløver	V 11	400	-19,0	19,0	29	11	15	2	Spar	S 6	100	-23,7	21,7	21	5	58	6	NT	S 11	100	-25,0	25,0
16	30	32	2	Hjertes	V 10	170	-26,0	26,0	22	42	44	4	Hjertes	Ø 11	650	-21,0	21,0	1	3	1	5	Kløver	V 11	400	-19,0	19,0	30	8	20	3	Ruter	S 7	100	-23,7	21,7	18	26	35	6	Spar	N 11	100	-25,0	25,0
34	66	68	2	Hjertes	V 10	170	-26,0	26,0	5	11	9	3	NT	Ø 11	660	-28,0	28,0	28	54	56	3	NT	Ø 10	430	-29,0	29,0	16	10	46	2	Kløver	Ø 9	110	-30,9	28,9	19	45	9	6	Spar	N 11	100	-25,0	25,0
14	26	28	3	Hjertes	V 10	170	-26,0	26,0	13	27	25	3	NT	Ø 11	660	-28,0	28,0	27	55	53	3	NT	V 10	430	-29,0	29,0	33	65	17	2	Kløver	Ø 9	110	-30,9	28,9	9	30	59	6	Spar	N 11	100	-25,0	25,0
29	59	57	2	NT	Ø 11	210	-31,0	31,0	23	47	45	3	NT	V 11	660	-28,0	28,0	21	43	41	3	NT	Ø 10	430	-29,0	29,0	18	26	35	2	Spar	V 8	110	-30,9	28,9	20	37	47	6	Spar	N 11	100	-25,0	25,0
4	6	8	2	NT	Ø 11	210	-31,0	31,0	21	43	41	2	Spar	D S 5	800	-32,0	32,0	33	67	65	3	NT	Ø 10	430	-29,0	29,0	34	44	53</															

SPILLSTENSILER NM Veteran, 03. august 2010

♠ A42 Mappenr: **21(21)**
♥ K8 Rundenr: **6**
♦ AKQJ5 NS (N)
♣ A84
♠ KJT3
♥ A63
♦ T7
♣ T652
♠ Q75
♥ T974
♦ 832
♣ QJ7

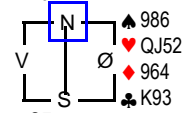

♠ T654 Mappenr: **22(22)**
♥ T53 Rundenr: **6**
♦ T7653 ØV (Ø)
♣ Q
♠ Q93
♥ Q
♦ KJ9
♣ AKJ742
♠ KJ872
♥ 986
♦ 8
♣ 9653

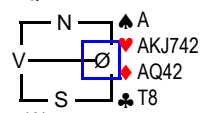

♠ T872 Mappenr: **23(23)**
♥ K98 Rundenr: **6**
♦ AQ A (S)
♣ KT82
♠ AQ943
♥ JT42
♦ KJT5
♣
♠ K5
♥ AQ
♦ 9763
♣ A9763

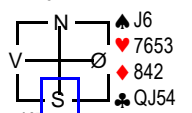

♠ T98542 Mappenr: **24(24)**
♥ J4 Rundenr: **6**
♦ A72 I (V)
♣ J8
♠ A76
♥ 8632
♦ J98
♣ K94
♠ QJ
♥ K975
♦ KQ5
♣ Q732

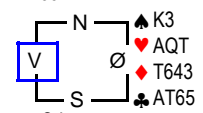

♠ AJ8 Mappenr: **25(25)**
♥ JT3 Rundenr: **7**
♦ AQ ØV (N)
♣ A8752
♠ KQ743
♥ AK98
♦ K32
♣ 9
♠ 92
♥ 654
♦ JT87
♣ JT43

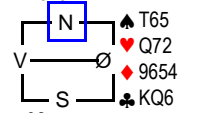

Bord	NS	ØV	NS	ØV	Bord	NS	ØV	NS	ØV	Bord	NS	ØV	NS	ØV	Bord	NS	ØV	NS	ØV	Bord	NS	ØV	NS	ØV	Bord	NS	ØV	NS	ØV											
29	34	39	3NT	N 10	630	32,0	-32,0	21	12	53	6NT	S 13	1020	32,0	-32,0	28	60	37	3NT	S 11	660	32,0	-32,0	3	46	1	2NT	D Ø	5	500	32,0	-32,0	30	4	65	1NT	V 5	200	30,0	-30,0
16	62	35	3NT	N 9	600	14,0	-14,0	11	36	57	6Ruter	Ø 9	300	30,0	-30,0	2	59	63	3NT	N 10	630	24,0	-24,0	19	33	55	2Spar	N 10	170	29,9	-29,9	31	3	39	2Kløver	V 6	200	30,0	-30,0	
20	23	58	3NT	N 9	600	14,0	-14,0	1	41	18	6Ruter	Ø 10	200	28,0	-28,0	10	64	25	3NT	S 10	630	24,0	-24,0	26	61	48	2Spar	N 9	140	25,8	-25,8	24	52	47	3Hjerter	Ø 7	200	30,0	-30,0	
17	43	16	3NT	N 9	600	14,0	-14,0	24	49	8	6Kløver	V 11	100	25,0	-25,0	8	40	15	3NT	S 10	630	24,0	-24,0	21	12	53	2Spar	N 9	140	25,8	-25,8	14	29	25	2NT	N 6	100	23,0	-23,0	
30	68	65	3NT	N 9	600	14,0	-14,0	13	45	24	6Ruter	Ø 11	100	25,0	-25,0	15	5	22	3NT	S 10	630	24,0	-24,0	4	54	19	2Spar	N 9	140	25,8	-25,8	18	20	23	3Kløver	S 7	100	23,0	-23,0	
13	45	24	3NT	N 9	600	14,0	-14,0	14	30	27	4Hjerter	Ø 13	710	22,0	-22,0	5	66	9	3NT	S 10	630	24,0	-24,0	15	5	22	2Spar	N 8	110	9,3	-9,3	10	40	50	3Kløver	S 7	100	23,0	-23,0	
18	52	29	3NT	N 9	600	14,0	-14,0	15	5	22	3NT	V 13	720	17,0	-17,0	19	33	55	3NT	N 10	630	24,0	-24,0	14	30	27	2Spar	N 8	110	9,3	-9,3	21	48	16	3Kløver	N 7	100	23,0	-23,0	
8	40	15	3NT	N 9	600	14,0	-14,0	20	23	58	3NT	V 13	720	17,0	-17,0	20	23	58	3NT	S 10	630	24,0	-24,0	23	47	2	2Spar	N 8	110	9,3	-9,3	1	19	59	2Hjerter	Ø 8	110	15,0	-15,0	
3	46	1	3NT	N 9	600	14,0	-14,0	9	56	42	3NT	V 13	720	17,0	-17,0	23	47	2	3NT	S 9	600	5,0	-5,0	22	21	6	2Spar	N 8	110	9,3	-9,3	28	2	8	2Hjerter	V 8	110	15,0	-15,0	
14	30	27	3NT	N 9	600	14,0	-14,0	27	4	20	4NT	Ø 13	720	17,0	-17,0	31	10	28	3NT	S 9	600	5,0	-5,0	24	49	8	2Spar	N 8	110	9,3	-9,3	23	49	62	2Hjerter	V 8	110	15,0	-15,0	
1	41	18	3NT	N 9	600	14,0	-14,0	31	10	28	6NT	Ø 12	1440	11,0	-11,0	26	61	48	3NT	S 9	600	5,0	-5,0	9	56	42	2Spar	N 8	110	9,3	-9,3	2	63	66	2Hjerter	Ø 8	110	15,0	-15,0	
25	38	67	3NT	N 9	600	14,0	-14,0	28	60	37	6NT	V 12	1440	11,0	-11,0	16	62	35	3NT	N 9	600	5,0	-5,0	28	60	37	2Spar	S 8	110	9,3	-9,3	7	54	32	2Hjerter	V 9	140	-7,0	7,0	
5	66	9	3NT	N 9	600	14,0	-14,0	17	43	16	6Hjerter	Ø 13	1460	4,0	-4,0	9	56	42	3NT	N 9	600	5,0	-5,0	27	4	20	2Spar	N 8	110	9,3	-9,3	20	38	68	2Hjerter	Ø 9	140	-7,0	7,0	
11	36	57	3NT	N 9	600	14,0	-14,0	22	21	6	6Hjerter	Ø 13	1460	4,0	-4,0	3	46	1	3NT	S 9	600	5,0	-5,0	11	36	57	2Spar	N 8	110	9,3	-9,3	22	55	5	2Hjerter	Ø 9	140	-7,0	7,0	
9	56	42	3NT	N 9	600	14,0	-14,0	12	51	32	6Hjerter	Ø 13	1460	4,0	-4,0	29	34	39	3NT	S 9	600	5,0	-5,0	25	38	67	2Spar	N 8	110	9,3	-9,3	32	10	60	2Hjerter	Ø 9	140	-7,0	7,0	
10	64	25	3NT	N 9	600	14,0	-14,0	25	38	67	6Hjerter	Ø 13	1460	4,0	-4,0	1	41	18	3NT	S 9	600	5,0	-5,0	32	3	17	2Spar	N 8	110	9,3	-9,3	5	9	56	2Hjerter	V 9	140	-7,0	7,0	
2	59	63	3NT	N 9	600	14,0	-14,0	6	50	14	6Hjerter	Ø 13	1460	4,0	-4,0	7	31	7	3NT	S 9	600	5,0	-5,0	13	45	24	2Spar	N 8	110	9,3	-9,3	13	24	64	2Hjerter	V 9	140	-7,0	7,0	
4	54	19	3NT	N 9	600	14,0	-14,0	8	40	15	6NT	V 13	1470	-13,0	13,0	11	36	57	3NT	S 9	600	5,0	-5,0	12	51	32	2Spar	N 8	110	9,3	-9,3	27	28	58	2Hjerter	V 9	140	-7,0	7,0	
15	5	22	2NT	N 9	150	-4,0	4,0	18	52	29	6NT	Ø 13	1470	-13,0	13,0	25	38	67	3NT	S 9	600	5,0	-5,0	5	66	9	40%-40%			-6,4	-6,4	6	1	31	2Hjerter	V 9	140	-7,0	7,0	
33	26	11	2NT	N 8	120	-6,0	6,0	30	68	65	6NT	V 13	1470	-13,0	13,0	32	3	17	3NT	S 9	600	5,0	-5,0	6	50	14	2NT	D Ø	7	100	-9,3	9,3	17	57	17	2Hjerter	Ø 9	140	-7,0	7,0
26	61	48	3NT	N 8	100	-17,0	17,0	23	47	2	6NT	V 13	1470	-13,0	13,0	4	54	19	4Hjerter	D V	8	500	-8,0	8,0	18	52	29	3Hjerter	V 7	100	-9,3	9,3	3	46	41	2Spar	V 9	140	-7,0	7,0
28	60	37	3NT	N 8	100	-17,0	17,0	16	62	35	6NT	V 13	1470	-13,0	13,0	13	45	24	1Spar	V 5	200	-10,0	10,0	31	10	28	3Hjerter	V 7	100	-9,3	9,3	12	67	21	2Spar	V 9	140	-7,0	7,0	
31	10	28	3NT	N 8	100	-17,0	17,0	2	59	63	6NT	Ø 13	1470	-13,0	13,0	6	50	14	2NT	N 10	180	-12,0	12,0	8	40	15	3Kløver	Ø 7	100	-9,3	9,3	8	45	42	2Spar	V 9	140	-7,0	7,0	
22	21	6	3NT	N 8	100	-17,0	17,0	29	34	39	6NT	V 13	1470	-13,0	13,0	21	12	53	1NT	N 9	150	-17,0	17,0	7	31	7	4Ruter	Ø 8	100	-9,3	9,3	4	7	18	2Spar	V 9	140	-7,0	7,0	
24	49	8	3NT	N 8	100	-17,0	17,0	3	46	1	6NT	Ø 13	1470	-13,0	13,0	17	43	16	2NT	N 9	150	-17,0	17,0	20	23	58	1Spar	V 6	50	-18,6	18,6	29	12	34	2Spar	V 9	140	-7,0	7,0	
23	47	2	3NT	N 8	100	-17,0	17,0	32	3	17	6NT	V 13	1470	-13,0	13,0	27	4	20	2NT	S 9	150	-17,0	17,0	29	34	39	2NT	V 7	50	-18,6	18,6	9	15	27	2Spar	V 9	140	-7,0	7,0	
19	33	55	3NT	N 8	100	-17,0	17,0	4	54	19	6NT	Ø 13	1470	-13,0	13,0	18	52	29	3Kløver	S 11	150	-17,0	17,0	10	64	25	3Kløver	Ø 8	50	-18,6	18,6	11	14	43	2Spar	V 9	140	-7,0	7,0	
6	50	14	3NT	N 8	100	-17,0	17,0	10	64	25	6NT	V 13	1470	-13,0	13,0	24	49	8	2Kløver	S 10	130	-22,0	22,0	30	68	65	3Ruter	Ø 8	50	-18,6	18,6	33	44	26	2Spar	V 9	140	-7,0	7,0	
27	4	20	3NT	N 8	100	-17,0	17,0	33	26	11	6NT	Ø 13	1470	-13,0	13,0	12	51	32	1Spar	N 7	80	-24,0	24,0	33	26	11	3Spar	N 8	50	-23,7	23,7	15	6	35	2Spar	V 9	140	-7,0	7,0	
32	3	17	3NT	N 8	100	-17,0	17,0	19	33	55	7NT	V 13	2220	-29,0	29,0	14	30	27	3NT	S 8	100	-29,0	29,0	17	43	16	1NT	Ø 7	90	-25,8	25,8	25	51	37	4Kløver	N 7	150	-26,0	26,0	
12	51	32	3NT	N 7	200	-30,0	30,0	7	31	7	7NT	V 13	2220	-29,0	29,0	22	21	6	3NT	S 8	100	-29,0	29,0	16	62	35	1NT	Ø 8	120	-28,9	28,9	26	22	53	2Spar	V 10	170	-29,0	29,0	
21	12	53	3NT	N 7	200	-30,0	30,0	26	61	48	7NT	V 13	2220	-29,0	29,0	30	68	65	3NT	S 8	100	-29,0	29,0	1	41	18	1NT	Ø 8	120	-28,9	28,9	19	61	30	2Spar	V 10	170	-29,0	29,0	
7	31	7	3NT	N 7	200	-30,0	30,0	5	66	9	7NT	V 13	2220	-29,0	29,0	33	26	11	3NT	S 8	100	-29,0	29,0	2	59	63	1NT	Ø 9	150	-32,0	32,0	16	36	33	1NT	D N	4	500	-32,0	32,0
34	44	13	WO					34	44	13	WO				34	44	13	WO						34	44	13	WO					34	11	13	WO					

SPILLSTENSILER NM Veteran, 03. august 2010

♠ 86 Mappenr: 26(26)
♥ Q6 Rundenr: 7
♦ AQ98 A (Ø)
♣ J9752

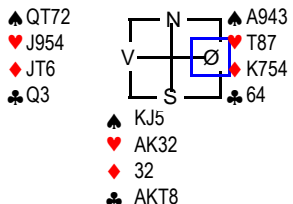

♠ J86 Mappenr: 27(27)
♥ KQJ Rundenr: 7
♦ 763 I (S)
♣ AKT5

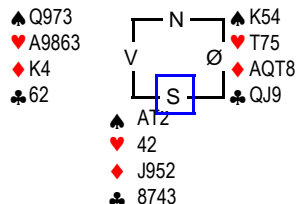

♠ K753 Mappenr: 28(28)
♥ AQ4 Rundenr: 7
♦ Q43 NS (V)
♣ AJ7

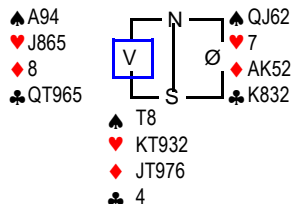

♠ AT Mappenr: 29(29)
♥ KT764 Rundenr: 8
♦ T9642 A (N)
♣ 4

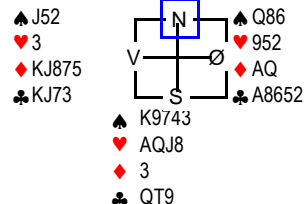

♠ 9 Mappenr: 30(30)
♥ KQT732 Rundenr: 8
♦ 82 I (Ø)
♣ 9542

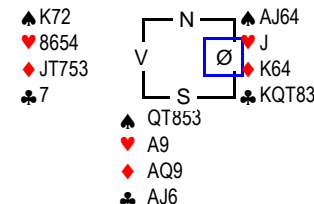

Bord		NS				ØV				NS		ØV				Bord		NS				ØV				NS		ØV				Bord		NS				ØV														
20	38	68	3	NT	S 12	690	31,0	-31,0	24	52	47	1	NT	D S 7	180	32,0	-32,0	17	57	17	3	NT	N 9	600	32,0	-32,0	1	7	46	4	Hjertes	N 11	650	29,9	-29,9	22	55	57	3	Kløver	D Ø 4	1100	32,0	-32,0								
2	63	66	3	NT	N 12	690	31,0	-31,0	29	12	34	1	NT	N 8	120	30,0	-30,0	31	3	39	3	Hjertes	N 10	170	30,0	-30,0	32	3	26	4	Hjertes	N 11	650	29,9	-29,9	14	25	43	3	Kløver	D Ø 5	800	29,9	-29,9								
9	15	27	3	NT	S 11	660	20,0	-20,0	15	6	35	1	NT	Ø 5	100	26,0	-26,0	10	40	50	2	Hjertes	N 9	140	9,0	-9,0	5	32	9	4	Hjertes	S 11	650	29,9	-29,9	5	32	9	3	NT	S 11	460	27,8	-27,8								
28	2	8	3	NT	N 11	660	20,0	-20,0	1	19	59	2	Spar	Ø 6	100	26,0	-26,0	26	22	53	2	Hjertes	S 9	140	9,0	-9,0	22	55	57	4	Hjertes	N 10	620	22,7	-22,7	21	61	49	4	Hjertes	N 11	450	22,7	-22,7								
12	67	21	3	NT	S 11	660	20,0	-20,0	6	1	31	3	NT	Ø 7	100	26,0	-26,0	6	1	31	2	Hjertes	N 9	140	9,0	-9,0	10	35	1	4	Hjertes	N 10	620	22,7	-22,7	30	58	22	4	Hjertes	N 11	450	22,7	-22,7								
25	51	37	3	NT	S 11	660	20,0	-20,0	9	15	27	1	NT	N 7	90	21,0	-21,0	19	61	30	2	Hjertes	N 9	140	9,0	-9,0	27	12	52	4	Hjertes	N 10	620	22,7	-22,7	17	50	67	4	Hjertes	N 11	450	22,7	-22,7								
22	55	5	3	NT	S 11	660	20,0	-20,0	12	67	21	1	NT	N 7	90	21,0	-21,0	23	49	62	2	Hjertes	S 9	140	9,0	-9,0	7	14	36	4	Hjertes	N 10	620	22,7	-22,7	1	7	46	4	Hjertes	N 11	450	22,7	-22,7								
24	52	47	3	NT	S 11	660	20,0	-20,0	4	7	18	1	Kløver	N 7	70	18,0	-18,0	15	6	35	2	Hjertes	N 9	140	9,0	-9,0	13	27	5	2	Hjertes	N 11	200	9,3	-9,3	2	41	63	4	Hjertes	S 10	420	16,5	-16,5								
19	61	30	3	NT	S 11	660	20,0	-20,0	17	57	17	1	NT	Ø 6	50	11,0	-11,0	12	67	21	2	Hjertes	N 9	140	9,0	-9,0	19	16	21	3	Hjertes	N 11	200	9,3	-9,3	16	42	33	4	Hjertes	S 10	420	16,5	-16,5								
32	10	60	3	NT	S 11	660	20,0	-20,0	26	22	53	2	Hjertes	V 7	50	11,0	-11,0	25	51	37	2	Hjertes	N 9	140	9,0	-9,0	31	60	39	3	Hjertes	N 11	200	9,3	-9,3	12	15	31	3	NT	S 9	400	12,4	-12,4								
23	49	62	3	NT	S 11	660	20,0	-20,0	3	46	41	2	Hjertes	V 7	50	11,0	-11,0	18	20	23	2	Hjertes	N 9	140	9,0	-9,0	21	61	49	3	Hjertes	N 11	200	9,3	-9,3	7	14	36	3	NT	S 9	400	12,4	-12,4								
13	24	64	3	NT	S 10	630	-4,0	4,0	5	9	56	2	Spar	V 7	50	11,0	-11,0	22	55	5	2	Hjertes	N 9	140	9,0	-9,0	23	2	28	3	Hjertes	S 11	200	9,3	-9,3	29	51	4	60%-50%			6,4	0,0	24	65	62	2	Hjertes	N 11	200	-1,0	1,0
10	40	50	3	NT	S 10	630	-4,0	4,0	25	51	37	3	Hjertes	V 8	50	11,0	-11,0	13	24	64	2	Hjertes	N 9	140	9,0	-9,0	8	18	40	3	Hjertes	N 11	200	9,3	-9,3	25	47	68	2	Hjertes	S 11	200	-1,0	1,0								
17	57	17	3	NT	S 10	630	-4,0	4,0	14	29	25	3	Hjertes	V 8	50	11,0	-11,0	4	7	18	2	Hjertes	N 9	140	9,0	-9,0	6	54	45	3	Hjertes	N 11	200	9,3	-9,3	4	19	66	2	Hjertes	N 11	200	-1,0	1,0								
8	45	42	3	NT	S 10	630	-4,0	4,0	2	63	66	1	NT	S 6	50	3,0	-3,0	33	44	26	2	Hjertes	N 9	140	9,0	-9,0	15	17	38	3	Kløver	Ø 7	200	9,3	-9,3	31	60	39	2	Hjertes	N 11	200	-1,0	1,0								
15	6	35	3	NT	S 10	630	-4,0	4,0	33	44	26	3	Kløver	N 8	50	3,0	-3,0	20	38	68	2	Hjertes	N 9	140	9,0	-9,0	2	41	63	5	Kløver	Ø 9	200	9,3	-9,3	28	34	37	2	Hjertes	N 11	200	-1,0	1,0								
7	54	32	3	NT	S 10	630	-4,0	4,0	18	20	23	1	Ruter	Ø 7	70	0,0	0,0	32	10	60	2	Hjertes	N 9	140	9,0	-9,0	29	51	4	60%-50%			6,4	0,0	24	65	62	2	Hjertes	N 11	200	-1,0	1,0									
18	20	23	3	NT	N 10	630	-4,0	4,0	21	48	16	1	NT	Ø 7	90	-3,0	3,0	21	48	16	2	Hjertes	N 9	140	9,0	-9,0	30	58	22	2	Hjertes	N 10	170	-8,3	8,3	8	18	40	3	Hjertes	N 11	200	-1,0	1,0								
5	9	56	3	NT	S 10	630	-4,0	4,0	31	3	39	1	NT	Ø 7	90	-3,0	3,0	29	12	34	2	Hjertes	S 9	140	9,0	-9,0	14	25	43	2	Hjertes	N 10	170	-8,3	8,3	19	16	21	3	Hjertes	N 11	200	-1,0	1,0								
16	36	33	3	NT	S 10	630	-4,0	4,0	32	10	60	2	NT	N 6	100	-7,0	7,0	11	14	43	2	Hjertes	N 9	140	9,0	-9,0	17	50	67	2	Hjertes	N 10	170	-8,3	8,3	3	56	59	3	Hjertes	N 11	200	-1,0	1,0								
4	7	18	3	NT	S 10	630	-4,0	4,0	19	61	30	3	Kløver	N 7	100	-7,0	7,0	3	46	41	3	Hjertes	N 9	140	9,0	-9,0	3	56	59	2	Hjertes	N 10	170	-8,3	8,3	13	27	5	3	Hjertes	N 11	200	-1,0	1,0								
31	3	39	3	NT	S 10	630	-4,0	4,0	30	4	65	1	Hjertes	V 8	110	-18,0	18,0	2	63	66	3	Hjertes	N 9	140	9,0	-9,0	9	29	6	3	Hjertes	N 10	170	-8,3	8,3	32	3	26	3	Hjertes	N 11	200	-1,0	1,0								
30	4	65	3	NT	S 10	630	-4,0	4,0	27	28	58	1	Hjertes	V 8	110	-18,0	18,0	24	52	47	2	Hjertes	N 8	110	-15,0	15,0	12	15	31	3	Hjertes	N 10	170	-8,3	8,3	11	64	23	3	Hjertes	N 11	200	-1,0	1,0								
21	48	16	3	NT	S 10	630	-4,0	4,0	11	14	43	2	Hjertes	Ø 8	110	-18,0	18,0	30	4	65	2	Hjertes	N 8	110	-15,0	15,0	24	65	62	3	Hjertes	S 10	170	-8,3	8,3	10	35	1	2	Hjertes	S 10	170	-19,6	19,6								
29	12	34	3	NT	S 10	630	-4,0	4,0	22	55	5	2	Hjertes	V 8	110	-18,0	18,0	28	2	8	3	Ruter	S 9	110	-15,0	15,0	25	47	68	3	Hjertes	S 10	170	-8,3	8,3	20	24	48	2	Hjertes	S 10	170	-19,6	19,6								
11	14	43	3	NT	S 10	630	-4,0	4,0	20	38	68	2	Hjertes	V 8	110	-18,0	18,0	16	36	33	3	Ruter	S 9	110	-15,0	15,0	26	53	8	2	Spar	N 9	140	-19,6	19,6	27	12	52	2	Hjertes	N 10	170	-19,6	19,6								
26	22	53	3	NT	N 9	600	-23,0	23,0	28	2	8	2	Hjertes	Ø 8	110	-18,0	18,0	8	45	42	2	Spar	Ø 7	50	-21,0	21,0	18	30	20	3	Hjertes	S 9	140	-19,6	19,6	6	54	45	2	Hjertes	S 10	170	-19,6	19,6								
1	19	59	3	NT	S 9	600	-23,0	23,0	7	54	32	2	Hjertes	V 8	110	-18,0	18,0	7	54	32	4	Kløver	Ø 9	50	-21,0	21,0	16	42	33	3	Spar	S 9	140	-19,6	19,6	9	29	6	3	Hjertes	S 10	170	-19,6	19,6								
14	29	25	3	NT	S 9	600	-23,0	23,0	13	24	64	2	Hjertes	V 8	110	-18,0	18,0	5	9	56	2	Spar	V 8	8	110	-24,0	24,0	33	11	44	1	Spar	S 8	110	-23,7	23,7	15	17	38	3	Hjertes	S 10	170	-19,6	19,6							
6	1	31	3	NT	S 9	600	-23,0	23,0	23	49	62	2	Hjertes	V 8	110	-18,0	18,0	9	15	27	3	Kløver	V 10	130	-26,0	26,0	28	34	37	2	Ruter	V 7	100	-26,8	26,8	23	2	28	3	Hjertes	S 10	170	-19,6	19,6								
27	28	58	3	Kløver	S 11	150	-28,0	28,0	10	40	50	1	NT	Ø 8	120	-28,0	28,0	14	29	25	3	Hjertes	S 7	200	-29,0	29,0	11	64	23	3	Kløver	Ø 8	100	-26,8	26,8	18	30	20	1	Spar	S 7	80	-27,8	27,8								
3	46	41	3	Kløver	S 10	130	-30,0	30,0	8	45	42	2	Hjertes	V 9	140	-30,0	30,0	1	19	59	4	Hjertes	D S 9	200	-29,0	29,0	20	24	48	4	Hjertes																					

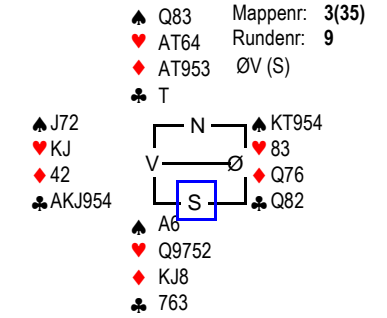
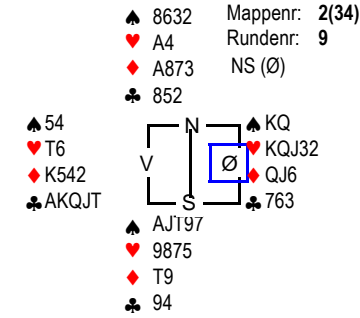
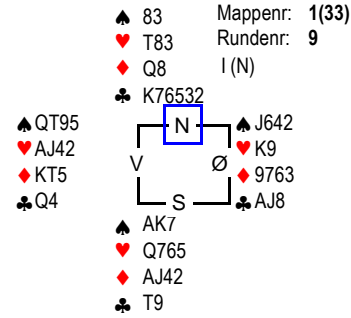
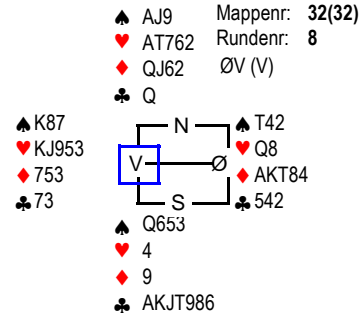
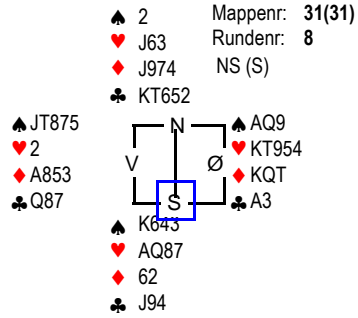

Bord	NS				ØV				NS	ØV				Bord	NS				ØV				NS	ØV				Bord	NS				ØV				NS	ØV											
	16	21	3	NT	Ø	6	150	29,9		-29,9	28	34	37		2	Ruter	D	Ø	5	800	32,0	-32,0		5	33	66	2		Kløver	V	7	50	31,0	-31,0	25	65		2	3	NT	Ø	7	100	18,0	-18,0	31	22	11	4
10	35	1	3	NT	Ø	6	150	29,9	-29,9	6	54	45	3	NT	N	12	490	25,8	-25,8	4	56	19	4	Spar	Ø	9	50	31,0	-31,0	11	45	15	3	NT	Ø	7	100	18,0	-18,0	5	33	66	4	Hjertes	S	10	420	29,0	-29,0
30	58	22	4	Spar	V	7	150	29,9	-29,9	25	47	68	3	NT	N	12	490	25,8	-25,8	12	20	25	1	Hjertes	S	6	50	26,0	-26,0	1	63	7	3	NT	Ø	7	100	18,0	-18,0	1	63	7	4	Hjertes	S	10	420	29,0	-29,0
20	24	48	3	NT	Ø	7	100	23,7	-23,7	21	61	49	3	NT	N	12	490	25,8	-25,8	31	22	11	1	NT	S	6	50	26,0	-26,0	12	20	25	3	NT	Ø	7	100	18,0	-18,0	18	23	52	4	Kløver	V	8	200	25,0	-25,0
28	34	37	4	Spar	Ø	8	100	23,7	-23,7	8	18	40	3	NT	N	12	490	25,8	-25,8	33	47	26	1	Ruter	S	6	50	26,0	-26,0	9	1	54	3	NT	Ø	7	100	18,0	-18,0	23	21	53	4	Spar	Ø	8	200	25,0	-25,0
14	25	43	4	Spar	V	8	100	23,7	-23,7	22	55	57	3	NT	N	12	490	25,8	-25,8	6	6	42	1	Spar	Ø	7	80	22,0	-22,0	32	28	44	3	NT	Ø	7	100	18,0	-18,0	30	34	60	2	Hjertes	S	10	170	21,0	-21,0
33	11	44	2	Hjertes	Ø	7	50	8,3	-8,3	23	2	28	3	NT	N	11	460	8,3	-8,3	14	38	35	3	Kløver	S	7	100	17,0	-17,0	5	33	66	3	NT	Ø	7	100	18,0	-18,0	19	36	58	3	Hjertes	N	10	170	21,0	-21,0
23	2	28	2	NT	Ø	7	50	8,3	-8,3	26	53	8	3	NT	N	11	460	8,3	-8,3	20	49	17	3	Kløver	N	7	100	17,0	-17,0	30	34	60	3	NT	Ø	7	100	18,0	-18,0	2	59	41	3	Hjertes	S	9	140	15,0	-15,0
8	18	40	3	NT	Ø	8	50	8,3	-8,3	1	7	46	3	NT	N	11	460	8,3	-8,3	18	23	52	3	Kløver	N	7	100	17,0	-17,0	28	62	4	3	NT	Ø	7	100	18,0	-18,0	32	28	44	3	Hjertes	S	9	140	15,0	-15,0
12	15	31	3	NT	Ø	8	50	8,3	-8,3	27	12	52	3	NT	S	11	460	8,3	-8,3	27	68	3	3	Kløver	S	7	100	17,0	-17,0	2	59	41	3	NT	Ø	7	100	18,0	-18,0	14	38	35	3	Hjertes	S	9	140	15,0	-15,0
5	32	9	3	NT	Ø	8	50	8,3	-8,3	5	32	9	3	NT	S	11	460	8,3	-8,3	17	5	50	1	Spar	Ø	8	110	10,0	-10,0	18	23	52	3	NT	Ø	7	100	18,0	-18,0	29	37	10	3	Hjertes	S	9	140	15,0	-15,0
9	29	6	3	NT	Ø	8	50	8,3	-8,3	32	3	26	3	NT	N	11	460	8,3	-8,3	32	28	44	1	Spar	Ø	8	110	10,0	-10,0	10	9	67	3	NT	Ø	7	100	18,0	-18,0	17	5	50	3	Ruter	N	10	130	10,0	-10,0
11	64	23	3	NT	Ø	8	50	8,3	-8,3	12	15	31	3	NT	N	11	460	8,3	-8,3	8	40	14	2	Spar	Ø	8	110	10,0	-10,0	19	36	58	3	NT	Ø	7	100	18,0	-18,0	8	40	14	2	Ruter	N	9	110	7,0	-7,0
32	3	26	3	NT	Ø	8	50	8,3	-8,3	33	11	44	3	NT	S	11	460	8,3	-8,3	28	62	4	1	Spar	Ø	9	140	2,0	-2,0	3	32	46	3	NT	Ø	7	100	18,0	-18,0	24	55	12	3	Ruter	N	9	110	7,0	-7,0
16	42	33	4	Spar	V	9	50	8,3	-8,3	4	19	66	3	NT	N	11	460	8,3	-8,3	21	16	57	2	Spar	Ø	9	140	2,0	-2,0	14	38	35	6	Kløver	V	10	100	18,0	-18,0	11	45	15	3	Spar	Ø	8	100	3,0	-3,0
4	19	66	4	Spar	V	9	50	8,3	-8,3	7	14	36	3	NT	N	11	460	8,3	-8,3	23	21	53	2	Spar	Ø	9	140	2,0	-2,0	23	21	53	3	NT	Ø	8	50	1,0	-1,0	10	9	67	3	Spar	Ø	8	100	3,0	-3,0
13	27	5	4	Spar	V	9	50	8,3	-8,3	11	64	23	3	NT	N	11	460	8,3	-8,3	13	43	29	3	Spar	Ø	9	140	2,0	-2,0	8	40	14	4	Hjertes	Ø	9	50	1,0	-1,0	13	43	29	3	Ruter	N	8	50	-5,0	5,0
2	41	63	4	Spar	V	9	50	8,3	-8,3	3	56	59	3	NT	N	11	460	8,3	-8,3	26	8	51	3	Spar	Ø	9	140	2,0	-2,0	13	43	29	3	Hjertes	Ø	10	170	-2,0	2,0	4	56	19	4	Hjertes	S	9	50	-5,0	5,0
29	51	4	60%-50%			6,4	0,0			29	51	4	60%-50%			6,4	0,0			25	65	2	1	Spar	Ø	10	170	-17,0	17,0	15	27	31	3	NT	Ø	9	400	-6,0	6,0	9	1	54	4	Hjertes	S	9	50	-5,0	5,0
21	61	49	1	Spar	V	9	140	-5,2	5,2	18	30	20	4	Spar	S	11	450	-6,2	6,2	19	36	58	1	Spar	Ø	10	170	-17,0	17,0	29	37	10	3	NT	Ø	9	400	-6,0	6,0	21	16	57	4	Hjertes	S	9	50	-5,0	5,0
26	53	8	3	Spar	V	10	170	-8,3	8,3	9	29	6	4	Spar	N	11	450	-6,2	6,2	2	59	41	1	Spar	Ø	10	170	-17,0	17,0	6	6	42	3	NT	Ø	9	400	-6,0	6,0	7	64	18	4	Hjertes	S	9	50	-5,0	5,0
15	17	38	3	Spar	V	10	170	-8,3	8,3	10	35	1	3	NT	S	10	430	-12,4	12,4	10	9	67	2	Spar	Ø	10	170	-17,0	17,0	21	16	57	4	Hjertes	Ø	10	420	-12,0	12,0	3	32	46	4	Hjertes	S	9	50	-5,0	5,0
1	7	46	4	Spar	V	10	420	-17,5	17,5	19	16	21	3	NT	S	10	430	-12,4	12,4	16	48	30	2	Spar	Ø	10	170	-17,0	17,0	26	8	51	4	Hjertes	Ø	10	420	-12,0	12,0	6	6	42	3	Ruter	N	7	100	-12,0	12,0
31	60	39	4	Spar	Ø	10	420	-17,5	17,5	31	60	39	3	NT	S	10	430	-12,4	12,4	24	55	12	2	Spar	Ø	10	170	-17,0	17,0	33	47	26	4	Hjertes	Ø	10	420	-12,0	12,0	15	27	31	2	Kløver	V	9	110	-14,0	14,0
7	14	36	4	Spar	V	10	420	-17,5	17,5	14	25	43	3	NT	S	10	430	-12,4	12,4	15	27	31	2	Spar	Ø	10	170	-17,0	17,0	22	24	61	3	NT	V	10	430	-21,0	21,0	20	49	17	3	Spar	V	9	140	-24,0	24,0
24	65	62	4	Spar	V	10	420	-17,5	17,5	24	65	62	4	Spar	S	10	420	-19,6	19,6	11	45	15	2	Spar	Ø	10	170	-17,0	17,0	7	64	18	3	NT	Ø	10	430	-21,0	21,0	25	65	2	3	Spar	Ø	9	140	-24,0	24,0
3	56	59	4	Spar	V	10	420	-17,5	17,5	15	17	38	4	Spar	S	10	420	-19,6	19,6	3	32	46	2	Spar	Ø	10	170	-17,0	17,0	31	22	11	3	NT	Ø	10	430	-21,0	21,0	16	48	30	3	Spar	Ø	9	140	-24,0	24,0
22	55	57	4	Spar	V	10	420	-17,5	17,5	17	50	67	4	Spar	S	10	420	-19,6	19,6	22	24	61	2	Spar	Ø	10	170	-17,0	17,0	4	56	19	3	NT	Ø	10	430	-21,0	21,0	28	62	4	3	Spar	Ø	9	140	-24,0	24,0
17	50	67	4	Spar	V	10	420	-17,5	17,5	20	24	48	5	Kløver	S	11	400	-23,7	23,7	30	34	60	3	Spar	Ø	10	170	-17,0	17,0	17	5	50	3	NT	V	10	430	-21,0	21,0	26	8	51	3	Spar	Ø	9	140	-24,0	24,0
25	47	68	3	NT	Ø	10	430	-25,8	25,8	16	42	33	3	Spar	S	11	200	-25,8	25,8	7	64	18	3	Spar	Ø	10	170	-17,0	17,0	27	68	3	3	NT	Ø	10	430	-21,0	21,0	27	68	3	3	Spar	Ø	9	140	-24,0	24,0
27	12	52	4	Spar	V	11	450	-28,9	28,9	2	41	63	3	Kløver	S	12	170	-28,9	28,9	9	1	54	3	Spar	Ø	10	170	-17,0	17,0	24	55	12	4	Hjertes	Ø	11	450	-28,0	28,0	22	24	61	3	Spar	Ø	9	140	-24,0	24,0
18	30	20	4	Spar	V	11	450	-28,9	28,9	13	27	5	4	Kløver	S	12	170	-28,9	28,9	29	37																												

SPILLSTENSILER NM Veteran, 03. august 2010

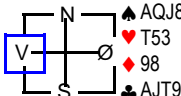
♠ T63 Mappen: 4(36)
 ♥ KQ4 Runden: 9
 ♦ AQ63 A (V)
 ♣ K65

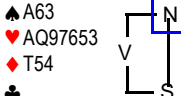
♠ QJT2 Mappen: 5(37)
 ♥ T Runden: 10
 ♦ AQJ82 NS (N)
 ♣ AT3

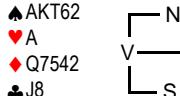
♠ 7 Mappen: 6(38)
 ♥ JT9652 Runden: 10
 ♦ J ØV (Ø)
 ♣ KQ732

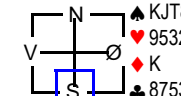
♠ Q73 Mappen: 7(39)
 ♥ K7 Runden: 10
 ♦ T9542 A (S)
 ♣ KJ9

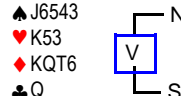
♠ 92 Mappen: 8(40)
 ♥ Q92 Runden: 10
 ♦ 942 I (V)
 ♣ KJ754

Bord	NS	ØV	NS	ØV	NS	ØV	Bord	NS	ØV	NS	ØV	Bord	NS	ØV	NS	ØV	Bord	NS	ØV	NS	ØV	Bord	NS	ØV	NS	ØV													
31	22	11	2NT	N 8	120	32,0	-32,0	30	22	10	4 Spar	D N 10	790	31,0	-31,0	27	57	34	5 Hjerter	D N 11	650	32,0	-32,0	26	30	24	4 Hjerter	V 9	100	31,0	-31,0	23	51	12	2 Spar	S 9	140	32,0	-32,0
26	8	51	1NT	N 7	90	24,0	-24,0	3	59	46	4 Spar	D N 10	790	31,0	-31,0	10	38	45	4 Hjerter	N 11	450	10,0	-10,0	17	29	58	5 Hjerter	V 10	100	31,0	-31,0	19	43	50	4 Hjerter	Ø 8	100	28,0	-28,0
5	33	66	1NT	N 7	90	24,0	-24,0	12	35	54	5 Hjerter	D V 9	300	28,0	-28,0	25	21	49	4 Hjerter	N 11	450	10,0	-10,0	31	28	11	4 Hjerter	V 10	620	11,0	-11,0	14	40	55	4 Spar	V 8	100	28,0	-28,0
32	28	44	1NT	N 7	90	24,0	-24,0	31	28	11	4 Hjerter	V 9	50	24,0	-24,0	18	16	31	4 Hjerter	N 11	450	10,0	-10,0	28	53	4	4 Hjerter	V 10	620	11,0	-11,0	11	42	64	4 Spar	V 8	100	28,0	-28,0
10	9	67	1NT	N 7	90	24,0	-24,0	22	62	2	4 Hjerter	V 9	50	24,0	-24,0	11	42	64	4 Hjerter	S 11	450	10,0	-10,0	15	5	61	4 Hjerter	V 10	620	11,0	-11,0	10	38	45	3 Hjerter	Ø 8	50	13,0	-13,0
16	48	30	1NT	N 7	90	24,0	-24,0	7	18	14	6 Kløver	Ø 11	50	24,0	-24,0	19	43	50	4 Hjerter	S 11	450	10,0	-10,0	13	52	1	4 Hjerter	V 10	620	11,0	-11,0	8	25	67	3 Hjerter	Ø 8	50	13,0	-13,0
24	55	12	1NT	N 7	90	24,0	-24,0	32	60	44	5 Ruter	N 10	100	19,0	-19,0	16	23	27	4 Hjerter	N 11	450	10,0	-10,0	4	41	19	4 Hjerter	V 10	620	11,0	-11,0	20	8	9	3 Hjerter	Ø 8	50	13,0	-13,0
33	47	26	1NT	N 7	90	24,0	-24,0	14	40	55	5 Ruter	N 10	100	19,0	-19,0	15	5	61	4 Hjerter	S 11	450	10,0	-10,0	11	42	64	4 Hjerter	V 10	620	11,0	-11,0	27	57	34	3 Hjerter	Ø 8	50	13,0	-13,0
28	62	4	1NT	V 7	90	13,0	-13,0	21	36	3	4 Kløver	Ø 12	170	16,0	-16,0	8	25	67	4 Hjerter	N 11	450	10,0	-10,0	16	23	27	4 Hjerter	V 10	620	11,0	-11,0	24	17	68	3 Spar	V 8	50	13,0	-13,0
1	63	7	1NT	V 7	90	13,0	-13,0	18	16	31	4 Spar	N 8	200	10,0	-10,0	2	63	56	4 Hjerter	N 11	450	10,0	-10,0	8	25	67	4 Hjerter	V 10	620	11,0	-11,0	12	35	54	3 Spar	V 8	50	13,0	-13,0
25	65	2	1NT	V 7	90	13,0	-13,0	1	7	32	5 Ruter	D N 10	200	10,0	-10,0	30	22	10	4 Hjerter	N 11	450	10,0	-10,0	29	37	65	4 Hjerter	V 10	620	11,0	-11,0	28	53	4	3 Spar	V 8	50	13,0	-13,0
19	36	58	1NT	V 7	90	13,0	-13,0	27	57	34	5 Ruter	D N 10	200	10,0	-10,0	1	7	32	4 Hjerter	N 11	450	10,0	-10,0	2	63	56	4 Hjerter	V 10	620	11,0	-11,0	33	39	26	4 Hjerter	Ø 9	50	13,0	-13,0
18	23	52	1NT	N 6	100	3,0	-3,0	20	8	9	5 Ruter	D N 10	200	10,0	-10,0	14	40	55	4 Hjerter	N 11	450	10,0	-10,0	7	18	14	4 Hjerter	V 10	620	11,0	-11,0	25	21	49	4 Hjerter	Ø 9	50	13,0	-13,0
7	64	18	1NT	N 6	100	3,0	-3,0	2	63	56	6 Ruter	D S 11	200	10,0	-10,0	17	29	58	4 Hjerter	N 11	450	10,0	-10,0	32	60	44	4 Hjerter	V 10	620	11,0	-11,0	2	63	56	4 Hjerter	Ø 9	50	13,0	-13,0
23	21	53	1 Ruter	N 6	100	3,0	-3,0	17	29	58	4 Hjerter	V 10	420	-3,0	3,0	12	35	54	4 Hjerter	N 11	450	10,0	-10,0	6	66	6	4 Hjerter	V 10	620	11,0	-11,0	5	33	20	4 Spar	V 9	50	13,0	-13,0
9	1	54	2 Hjerter	S 7	100	3,0	-3,0	15	5	61	5 Kløver	Ø 12	420	-3,0	3,0	28	53	4	4 Hjerter	N 11	450	10,0	-10,0	33	39	26	4 Hjerter	V 10	620	11,0	-11,0	7	18	14	4 Spar	V 9	50	13,0	-13,0
12	20	25	2 Hjerter	S 7	100	3,0	-3,0	13	52	1	5 Kløver	Ø 12	420	-3,0	3,0	7	18	14	4 Hjerter	S 11	450	10,0	-10,0	30	22	10	4 Hjerter	V 10	620	11,0	-11,0	18	16	31	Pass			0,0	0,0
21	16	57	2 Hjerter	S 7	100	3,0	-3,0	23	51	12	5 Kløver	Ø 12	420	-3,0	3,0	4	41	19	4 Hjerter	S 11	450	10,0	-10,0	24	17	68	4 Hjerter	V 10	620	11,0	-11,0	26	30	24	2 Spar	V 8	110	-4,0	4,0
13	43	29	1 Spar	Ø 8	110	-5,0	5,0	28	53	4	5 Kløver	Ø 12	420	-3,0	3,0	5	33	20	5 Hjerter	N 11	450	10,0	-10,0	27	57	34	4 Hjerter	V 10	620	11,0	-11,0	6	66	6	2 Spar	V 8	110	-4,0	4,0
8	40	14	2 Spar	Ø 8	110	-5,0	5,0	5	33	20	5 Kløver	Ø 12	420	-3,0	3,0	21	36	3	5 Hjerter	N 11	450	10,0	-10,0	21	36	3	4 Hjerter	V 10	620	11,0	-11,0	31	28	11	2 Spar	V 8	110	-4,0	4,0
15	27	31	1NT	V 8	120	-15,0	15,0	33	39	26	5 Kløver	Ø 12	420	-3,0	3,0	6	66	6	5 Hjerter	N 11	450	10,0	-10,0	3	59	46	4 Hjerter	V 11	650	-20,0	20,0	22	62	2	2 Spar	V 9	140	-19,0	19,0
4	56	19	1NT	V 8	120	-15,0	15,0	10	38	45	5 Kløver	Ø 12	420	-3,0	3,0	20	8	9	5 Hjerter	N 11	450	10,0	-10,0	23	51	12	4 Hjerter	V 11	650	-20,0	20,0	1	7	32	3 Hjerter	Ø 9	140	-19,0	19,0
2	59	41	1NT	V 8	120	-15,0	15,0	26	30	24	5 Kløver	D Ø 11	550	-12,0	12,0	23	51	12	4 Hjerter	N 10	420	-14,0	14,0	19	43	50	4 Hjerter	V 11	650	-20,0	20,0	13	52	1	3 Hjerter	Ø 9	140	-19,0	19,0
22	24	61	1NT	V 8	120	-15,0	15,0	8	25	67	5 Kløver	D Ø 12	650	-23,0	23,0	13	52	1	4 Hjerter	N 10	420	-14,0	14,0	25	21	49	4 Hjerter	V 11	650	-20,0	20,0	17	29	58	3 Hjerter	Ø 9	140	-19,0	19,0
6	6	42	1NT	V 8	120	-15,0	15,0	9	48	15	5 Kløver	D Ø 12	650	-23,0	23,0	3	59	46	4 Hjerter	N 10	420	-14,0	14,0	5	33	20	4 Hjerter	V 11	650	-20,0	20,0	3	59	46	3 Spar	Ø 9	140	-19,0	19,0
3	32	46	1NT	V 8	120	-15,0	15,0	11	42	64	5 Kløver	D Ø 12	650	-23,0	23,0	31	28	11	4 Spar	D V 9	200	-18,0	18,0	14	40	55	4 Hjerter	V 11	650	-20,0	20,0	21	36	3	3 Spar	V 9	140	-19,0	19,0
30	34	60	1NT	V 8	120	-15,0	15,0	29	37	65	5 Kløver	D Ø 12	650	-23,0	23,0	9	48	15	4 Spar	Ø 9	100	-20,0	20,0	20	8	9	4 Hjerter	V 11	650	-20,0	20,0	15	5	61	3 Spar	V 9	140	-19,0	19,0
29	37	10	1NT	V 8	120	-15,0	15,0	25	21	49	5 Kløver	D Ø 12	650	-23,0	23,0	32	60	44	5 Hjerter	N 10	50	-22,0	22,0	1	7	32	4 Hjerter	V 11	650	-20,0	20,0	32	60	44	3 Spar	V 9	140	-19,0	19,0
17	5	50	1NT	V 9	150	-25,0	25,0	6	66	6	5 Kløver	D V 12	650	-23,0	23,0	26	30	24	3 Ruter	S 7	100	-24,0	24,0	12	35	54	4 Hjerter	V 11	650	-20,0	20,0	9	48	15	3 Spar	V 9	140	-19,0	19,0
11	45	15	1NT	V 9	150	-25,0	25,0	19	43	50	5 Kløver	D Ø 12	650	-23,0	23,0	22	62	2	5 Ruter	D S 9	300	-26,0	26,0	22	62	2	4 Hjerter	V 11	650	-20,0	20,0	4	41	19	3 Spar	V 9	140	-19,0	19,0
20	49	17	1 Ruter	N 5	200	-30,0	30,0	16	23	27	5 Kløver	D Ø 12	650	-23,0	23,0	33	39	26	4 Spar	D V 10	790	-29,0	29,0	18	16	31	4 Hjerter	V 11	650	-20,0	20,0	16	23	27	3 Spar	Ø 9	140	-19,0	19,0
27	68	3	1 Ruter	D N 6	200	-30,0	30,0	4	41	19	5 Kløver	D Ø 12	650	-23,0	23,0	24	17	68	4 Spar	D V 10	790	-29,0	29,0	10	38	45	4 Hjerter	V 11	650	-20,0	20,0	30	22	10	3 Spar	V 9	140	-19,0	19,0
14	38	35	2 Hjerter	S 6	200	-30,0	30,0	24	17	68	5 Kløver	D Ø 12	650	-23,0	23,0	29	37	65	6NT	D S 7	1100	-32,0	32,0	9	48	15	4 Hjerter	V 11	650	-20,0	20,0	29	37	65	3 Ruter	S 6	150	-32,0	32,0
34	39	13	WO					34	47	13	WO					34	47	13	WO					34	47	13	WO												

SPILLSTENSILER NM Veteran, 03. august 2010

♠ Q7 Mappen: 9(41)
♥ K987642 Runden: 11
♦ A ØV (N)
♣ T86

♠ AK2 T83
♥ JT ♥ A3
♦ KJ87654 ♦ QT92
♣ J ♣ Q974

♠ J9654
♥ Q5
♦ 3
♣ AK532

♠ KJ543 Mappen: 10(42)
♥ K73 Runden: 11
♦ 8 A (Ø)
♣ AJ76

♠ 82 AT76
♥ A ♥ QJ52
♦ KQJ96 ♦ A
♣ T9543 ♣ KQ82

♠ Q9
♥ T9864
♦ T75432
♣

♠ KJT Mappen: 11(43)
♥ QJT952 Runden: 11
♦ K5 I (S)
♣ Q2

♠ Q5 83
♥ A876 ♥ K3
♦ AQT2 ♦ 8764
♣ T84 ♣ K9765

♠ A97642
♥ 4
♦ J93
♣ AJ3

♠ AQ5 Mappen: 12(44)
♥ 98 Runden: 11
♦ JT NS (V)
♣ AKQ654

♠ JT96 K8742
♥ AKQ2 ♥ J65
♦ 874 ♦ Q932
♣ J7 ♣ 8

♠ 3
♥ T743
♦ AK65
♣ T932

♠ KT5 Mappen: 13(45)
♥ KJ65 Runden: 12
♦ AJ52 A (N)
♣ Q3

♠ AJ7432 8
♥ A8 ♥ Q7
♦ 984 ♦ QT63
♣ 94 ♣ AKJT82

♠ Q96
♥ T9432
♦ K7
♣ 765

Bord	NS				ØV				NS	ØV				Bord	NS				ØV				NS	ØV				Bord	NS				ØV				NS	ØV												
	NS	ØV	NS	ØV	NS	ØV	NS	ØV		NS	ØV	NS	ØV		NS	ØV	NS	ØV	NS	ØV	NS	ØV		NS	ØV	NS	ØV		NS	ØV	NS	ØV	NS	ØV	NS	ØV		NS	ØV	NS	ØV									
1	33	63	4	NT	Ø	5	500	29,0	-29,0	14	3	29	3	NT	Ø	6	300	32,0	-32,0	21	58	8	4	Hjerner	N	11	450	23,0	-23,0	20	43	30	3	NT	N	12	690	32,0	-32,0	1	63	32	3	Spar	V	7	200	32,0	-32,0	
10	31	25	5	Ruter	D	V	9	500	29,0	-29,0	25	52	22	3	NT	Ø	7	200	30,0	-30,0	25	52	22	4	Spar	S	11	450	23,0	-23,0	24	57	51	3	NT	S	11	660	30,0	-30,0	20	8	64	2	Spar	V	7	100	26,0	-26,0
28	4	10	5	Ruter	D	V	9	500	29,0	-29,0	23	2	27	3	NT	Ø	8	100	20,0	-20,0	8	23	14	4	Spar	S	11	450	23,0	-23,0	28	4	10	5	Kløver	N	13	640	28,0	-28,0	17	5	57	3	NT	Ø	8	100	26,0	-26,0
2	7	59	5	Ruter	D	V	9	500	29,0	-29,0	27	34	65	3	NT	Ø	8	100	20,0	-20,0	10	31	25	4	Spar	S	11	450	23,0	-23,0	17	64	66	3	NT	N	10	630	25,0	-25,0	9	56	23	3	Spar	V	8	100	26,0	-26,0
26	12	28	4	Hjerner	N	10	420	20,0	-20,0	26	12	28	3	NT	Ø	8	100	20,0	-20,0	17	64	66	4	Spar	S	11	450	23,0	-23,0	16	50	55	3	NT	S	10	630	25,0	-25,0	33	44	47	3	Spar	V	8	100	26,0	-26,0	
9	38	42	4	Hjerner	N	10	420	20,0	-20,0	9	38	42	3	NT	Ø	8	100	20,0	-20,0	28	4	10	4	Spar	S	11	450	23,0	-23,0	3	32	41	3	NT	S	9	600	19,0	-19,0	24	58	51	3	Spar	V	8	100	26,0	-26,0	
27	34	65	4	Hjerner	N	10	420	20,0	-20,0	10	31	25	3	NT	Ø	8	100	20,0	-20,0	23	2	27	4	Spar	S	11	450	23,0	-23,0	12	45	1	5	Kløver	N	11	600	19,0	-19,0	30	39	24	3	Hjerner	S	8	100	19,0	-19,0	
19	16	5	4	Hjerner	N	10	420	20,0	-20,0	8	23	14	3	NT	Ø	8	100	20,0	-20,0	9	38	42	4	Spar	S	11	450	23,0	-23,0	5	20	56	5	Kløver	N	11	600	19,0	-19,0	15	2	3	3	Hjerner	N	8	100	19,0	-19,0	
8	23	14	4	Hjerner	N	10	420	20,0	-20,0	7	6	15	3	NT	Ø	8	100	20,0	-20,0	16	50	55	4	Spar	S	11	450	23,0	-23,0	4	46	18	5	Kløver	N	11	600	19,0	-19,0	25	21	48	2	Spar	V	8	100	2,0	-2,0	
15	48	17	5	Ruter	V	9	200	12,0	-12,0	5	20	56	3	NT	Ø	8	100	20,0	-20,0	26	12	28	4	Spar	S	11	450	23,0	-23,0	1	33	63	4	Spar	D	Ø	8	300	13,0	-13,0	22	65	30	3	Kløver	Ø	9	110	2,0	-2,0
18	9	36	5	Ruter	V	9	200	12,0	-12,0	21	58	8	5	Kløver	Ø	10	100	20,0	-20,0	31	11	47	4	Spar	S	10	420	9,0	-9,0	13	35	40	4	Spar	D	Ø	8	300	13,0	-13,0	12	31	45	3	Kløver	Ø	9	110	2,0	-2,0
22	62	21	5	Ruter	V	9	200	12,0	-12,0	28	4	10	2	Kløver	Ø	9	110	10,0	-10,0	30	49	37	4	Spar	S	10	420	9,0	-9,0	23	2	27	1	NT	N	10	180	6,0	-6,0	8	42	40	3	Kløver	Ø	9	110	2,0	-2,0	
14	3	29	3	Hjerner	N	10	170	8,0	-8,0	2	7	59	2	Kløver	Ø	11	150	7,0	-7,0	7	6	15	4	Spar	S	10	420	9,0	-9,0	2	7	59	1	NT	N	10	180	6,0	-6,0	6	61	41	3	Kløver	Ø	9	110	2,0	-2,0	
6	19	61	3	Hjerner	N	9	140	6,0	-6,0	3	32	41	3	Kløver	Ø	11	150	7,0	-7,0	24	57	51	4	Spar	S	10	420	9,0	-9,0	31	11	47	1	NT	N	10	180	6,0	-6,0	7	6	14	3	Kløver	Ø	9	110	2,0	-2,0	
32	26	60	5	Ruter	V	10	100	-3,0	3,0	6	19	61	3	Hjerner	D	S	7	500	4,0	-4,0	27	34	65	2	Spar	S	12	230	4,0	-4,0	29	53	68	1	NT	N	10	180	6,0	-6,0	28	68	49	3	Kløver	Ø	9	110	2,0	-2,0
3	32	41	5	Ruter	V	10	100	-3,0	3,0	11	67	54	3	NT	Ø	9	600	-3,0	3,0	13	35	40	2	Spar	S	11	200	-4,0	4,0	7	6	15	2	NT	N	10	180	6,0	-6,0	29	4	34	3	Kløver	Ø	9	110	2,0	-2,0	
12	45	1	5	Ruter	V	10	100	-3,0	3,0	13	35	40	3	NT	Ø	9	600	-3,0	3,0	12	45	1	2	Spar	S	11	200	-4,0	4,0	25	52	22	2	Kløver	N	12	170	-5,0	5,0	32	60	11	3	Kløver	Ø	9	110	2,0	-2,0	
13	35	40	5	Ruter	Ø	10	100	-3,0	3,0	15	48	17	3	NT	V	9	600	-3,0	3,0	3	32	41	2	Spar	N	11	200	-4,0	4,0	30	49	37	3	Kløver	N	12	170	-5,0	5,0	11	1	29	3	Kløver	Ø	9	110	2,0	-2,0	
4	46	18	5	Ruter	V	10	100	-3,0	3,0	18	9	36	5	Kløver	Ø	11	600	-3,0	3,0	5	20	56	3	Spar	S	11	200	-4,0	4,0	10	31	25	4	Kløver	N	12	170	-5,0	5,0	10	25	35	3	Kløver	Ø	9	110	2,0	-2,0	
17	64	66	5	Ruter	V	10	100	-3,0	3,0	33	44	39	5	Kløver	Ø	11	600	-3,0	3,0	1	33	63	3	Spar	S	11	200	-4,0	4,0	19	16	5	4	Kløver	N	12	170	-5,0	5,0	2	33	7	3	Kløver	Ø	9	110	2,0	-2,0	
11	67	54	5	Ruter	V	10	100	-3,0	3,0	16	50	55	5	Kløver	Ø	11	600	-3,0	3,0	15	48	17	3	Spar	S	11	200	-4,0	4,0	26	12	28	4	Kløver	N	12	170	-5,0	5,0	31	10	26	3	Kløver	Ø	9	110	2,0	-2,0	
5	20	56	5	Ruter	V	10	100	-3,0	3,0	22	62	21	3	NT	Ø	10	630	-17,0	17,0	18	9	36	3	Spar	S	11	200	-4,0	4,0	18	9	36	4	Kløver	N	12	170	-5,0	5,0	5	20	59	3	Kløver	Ø	9	110	2,0	-2,0	
23	2	27	4	Hjerner	N	9	50	-14,0	14,0	31	11	47	3	NT	V	10	630	-17,0	17,0	29	53	68	2	Spar	S	10	170	-20,0	20,0	11	67	54	3	Kløver	N	11	150	-18,0	18,0	19	17	27	3	Kløver	Ø	9	110	2,0	-2,0	
20	43	30	5	Hjerner	N	10	50	-14,0	14,0	12	45	1	3	NT	Ø	10	630	-17,0	17,0	19	16	5	2	Spar	N	10	170	-20,0	20,0	27	34	65	3	Kløver	S	11	150	-18,0	18,0	27	52	53	3	Kløver	Ø	10	130	-16,0	16,0	
16	50	55	5	Hjerner	N	10	50	-14,0	14,0	4	46	18	3	NT	Ø	10	630	-17,0	17,0	22	62	21	2	Spar	N	10	170	-20,0	20,0	15	48	17	3	Kløver	N	11	150	-18,0	18,0	26	28	62	3	Kløver	Ø	10	130	-16,0	16,0	
24	57	51	5	Hjerner	D	S	10	100	-19,0	19,0	24	57	51	3	NT	Ø	10	630	-17,0	17,0	11	67	54	2	Spar	N	10	170	-20,0	20,0	8	23	14	3	Kløver	N	11	150	-18,0	18,0	16	66	38	3	Kløver	Ø	10	130	-16,0	16,0
25	52	22	5	Hjerner	N	9	100	-19,0	19,0	17	64	66	3	NT	Ø	10	630	-17,0	17,0	20	43	30	2	Spar	S	10	170	-20,0	20,0	22	62	21	3	Kløver	N	11	150	-18,0	18,0	13	67	36	3	Spar	V	9	140	-20,0	20,0	
31	11	47	4	Ruter	V	10	130	-23,0	23,0	20	43	30	3	NT	Ø	10	630	-17,0	17,0	14	3	29	2	Spar	N	10	170	-20,0	20,0	33	44	39	4	Kløver	N	11	150	-18,0	18,0	4	46	19	2	NT	Ø	10	180	-22,0	22,0	
29	53	68	4	Ruter	V	10	130	-23,0	23,0	30	49	37	3	NT	Ø	10	630	-17,0	17,0	6	19	61	2	Spar	N	10	170	-20,0	20,0	9	38	42	4	Kløver	N	11	150	-18,0	18,0	14	54	50	3	Hjerner	N	7	200	-26,0	26,0	
30	49	37	5	Ruter	V	11	600	-29,0	29,0	19	16	5	3	NT	Ø	11	660	-26,0	26,0	32	26	60	2	Spar	S	10	170	-20,0	20,0	32	26	60	3	Spar	Ø	8	50	-27,0	27,0	3	15	18	3	Hjerner	N	7	200	-26,0	26,0	
33	44	39	5	Ruter	V	11	600	-29,0	29,0	1	33	63	2	Spar	D	N	5	800	-29,0	29,0	4	46	18	3	Spar	S	10	170	-20,0	20,0																				

SPILLSTENSILER NM Veteran, 03. august 2010

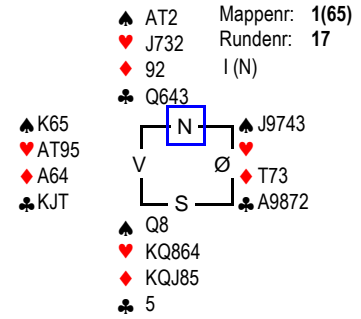
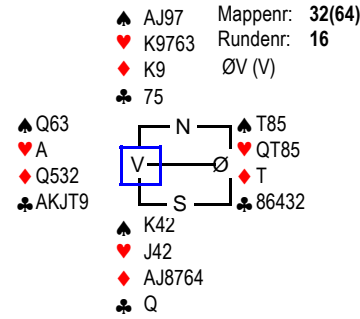
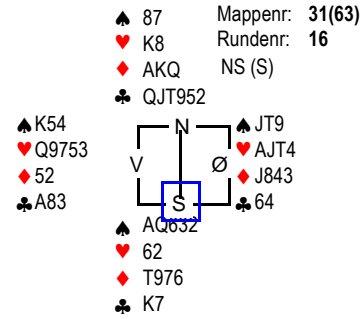
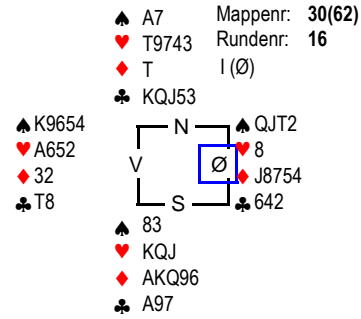
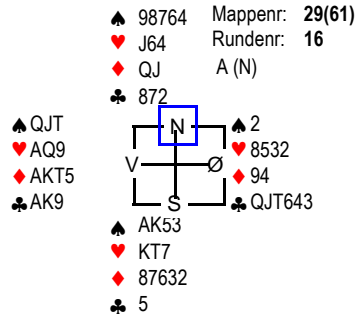

Bord	NS	ØV	NS	ØV	NS	ØV	Bord	NS	ØV	NS	ØV	Bord	NS	ØV	NS	ØV	Bord	NS	ØV	NS	ØV	Bord	NS	ØV	NS	ØV	Bord	NS	ØV	NS	ØV													
28	34	51	7	Kløver	D Ø12	200	32,0	-32,0	23	9	57	6	Hjerner	N12	980	27,0	-27,0	16	25	41	3	NT	N10	630	31,0	-31,0	29	47	28	5	Kløver	D V 9	500	32,0	-32,0	29	44	52	4	Hjerner	D N10	590	32,0	-32,0
2	63	31	3	Hjerner	Ø 9	140	30,0	-30,0	13	35	12	6	Hjerner	S12	980	27,0	-27,0	6	38	2	3	NT	N10	630	31,0	-31,0	16	25	41	3	Ruter	D S 9	470	30,0	-30,0	10	40	2	3	Hjerner	D S 9	530	24,0	-24,0
19	21	45	4	Kløver	V11	150	28,0	-28,0	5	33	50	6	Hjerner	N12	980	27,0	-27,0	31	22	26	3	NT	N 9	600	28,0	-28,0	13	35	12	2	Hjerner	N 9	140	19,0	-19,0	23	43	53	3	Hjerner	D S 9	530	24,0	-24,0
20	66	42	2	NT	V11	210	24,0	-24,0	25	14	53	6	Hjerner	N12	980	27,0	-27,0	18	36	16	3	Spar	S 9	140	26,0	-26,0	26	65	52	2	Hjerner	N 9	140	19,0	-19,0	8	6	59	3	Hjerner	D S 9	530	24,0	-24,0
26	65	52	2	NT	V11	210	24,0	-24,0	12	40	46	6	Hjerner	S12	980	27,0	-27,0	9	1	15	3	Kløver	N10	130	23,0	-23,0	32	10	39	2	Hjerner	N 9	140	19,0	-19,0	14	46	66	3	Hjerner	D S 9	530	24,0	-24,0
32	10	39	2	NT	V11	210	24,0	-24,0	28	34	51	6	Hjerner	S12	980	27,0	-27,0	32	10	39	3	Kløver	N10	130	23,0	-23,0	20	66	42	3	Hjerner	N 9	140	19,0	-19,0	12	64	56	3	Hjerner	D N 9	530	24,0	-24,0
4	6	7	5	Kløver	V11	600	19,0	-19,0	10	19	55	3	NT	S13	520	20,0	-20,0	22	3	67	2	NT	N 8	120	20,0	-20,0	27	37	4	3	Hjerner	N 9	140	19,0	-19,0	18	17	42	3	Hjerner	D S 9	530	24,0	-24,0
18	36	16	5	Kløver	V11	600	19,0	-19,0	1	18	61	3	NT	S12	490	18,0	-18,0	3	20	32	2	Kløver	N 9	110	11,0	-11,0	25	14	53	3	Hjerner	N 9	140	19,0	-19,0	20	68	4	3	Hjerner	D S 9	530	24,0	-24,0
29	47	28	4	Hjerner	V10	620	16,0	-16,0	16	25	41	4	Hjerner	N12	480	-1,0	1,0	24	27	54	2	Kløver	N 9	110	11,0	-11,0	19	21	45	3	Hjerner	N 9	140	19,0	-19,0	9	29	62	2	Hjerner	S10	170	16,0	-16,0
10	19	55	3	NT	V10	630	10,0	-10,0	11	5	56	4	Hjerner	S12	480	-1,0	1,0	13	35	12	2	Kløver	N 9	110	11,0	-11,0	12	40	46	3	Hjerner	N 9	140	19,0	-19,0	31	49	39	3	Hjerner	S 9	140	10,0	-10,0
23	9	57	3	NT	V10	630	10,0	-10,0	26	65	52	4	Hjerner	N12	480	-1,0	1,0	20	66	42	2	Spar	S 8	110	11,0	-11,0	14	62	58	3	Hjerner	N 9	140	19,0	-19,0	13	58	21	3	Hjerner	S 9	140	10,0	-10,0
24	27	54	3	NT	V10	630	10,0	-10,0	6	38	2	4	Hjerner	S12	480	-1,0	1,0	26	65	52	2	Spar	S 8	110	11,0	-11,0	17	43	68	3	Hjerner	N 9	140	19,0	-19,0	28	51	47	3	Hjerner	S 9	140	10,0	-10,0
8	59	23	3	NT	V10	630	10,0	-10,0	17	43	68	4	Hjerner	N12	480	-1,0	1,0	10	19	55	2	Spar	S 8	110	11,0	-11,0	4	6	7	2	Ruter	S 9	110	4,0	-4,0	26	28	65	3	Hjerner	S 9	140	10,0	-10,0
25	14	53	3	NT	V10	630	10,0	-10,0	22	3	67	4	Hjerner	N12	480	-1,0	1,0	2	63	31	2	Spar	S 8	110	11,0	-11,0	28	34	51	2	Ruter	S 9	110	4,0	-4,0	4	7	55	3	Hjerner	S 9	140	10,0	-10,0
22	3	67	3	NT	V11	660	-12,0	12,0	2	63	31	4	Hjerner	N12	480	-1,0	1,0	11	5	56	3	Kløver	N 9	110	11,0	-11,0	30	11	49	3	Ruter	S 9	110	4,0	-4,0	33	26	48	2	Hjerner	S 8	110	4,0	-4,0
27	37	4	3	NT	Ø11	660	-12,0	12,0	20	66	42	4	Hjerner	N12	480	-1,0	1,0	12	40	46	3	NT	N 8	100	-4,0	4,0	15	8	60	3	Ruter	S 9	110	4,0	-4,0	25	9	3	4	Spar	D Ø 9	100	-3,0	3,0
3	20	32	3	NT	V11	660	-12,0	12,0	15	8	60	4	Hjerner	S12	480	-1,0	1,0	5	33	50	3	NT	N 8	100	-4,0	4,0	11	5	56	3	Ruter	S 9	110	4,0	-4,0	11	23	1	4	Spar	Ø 8	100	-3,0	3,0
11	5	56	3	NT	V11	660	-12,0	12,0	21	30	17	4	Hjerner	N12	480	-1,0	1,0	23	9	57	3	NT	N 8	100	-4,0	4,0	7	29	64	4	Kløver	Ø 9	100	-5,0	5,0	24	67	45	4	Spar	Ø 8	100	-3,0	3,0
33	24	44	3	NT	V11	660	-12,0	12,0	31	22	26	4	Hjerner	N12	480	-1,0	1,0	1	18	61	3	NT	N 8	100	-4,0	4,0	31	22	26	4	Kløver	V 9	100	-5,0	5,0	5	32	61	4	Spar	Ø 8	100	-3,0	3,0
6	38	2	3	NT	V11	660	-12,0	12,0	4	6	7	4	Hjerner	N12	480	-1,0	1,0	33	24	44	3	Spar	S 8	100	-4,0	4,0	10	19	55	4	Kløver	V 9	100	-5,0	5,0	2	15	63	4	Spar	Ø 8	100	-3,0	3,0
5	33	50	3	NT	V11	660	-12,0	12,0	24	27	54	4	Hjerner	N12	480	-1,0	1,0	17	43	68	3	Spar	N 8	100	-4,0	4,0	33	24	44	4	Kløver	V 9	100	-5,0	5,0	7	5	19	4	Spar	Ø 8	100	-3,0	3,0
16	25	41	3	NT	V11	660	-12,0	12,0	18	36	16	4	Hjerner	N12	480	-1,0	1,0	7	29	64	3	Spar	N 8	100	-4,0	4,0	22	3	67	2	Ruter	S 8	90	-10,0	10,0	6	31	33	3	Spar	Ø 8	50	-11,0	11,0
17	43	68	3	NT	V11	660	-12,0	12,0	3	20	32	4	Hjerner	N12	480	-1,0	1,0	21	30	17	3	Hjerner	Ø 9	140	-13,0	13,0	9	1	15	4	Hjerner	N 9	50	-16,0	16,0	16	25	12	4	Spar	Ø 9	50	-11,0	11,0
31	22	26	3	NT	V11	660	-12,0	12,0	19	21	45	4	Hjerner	N12	480	-1,0	1,0	25	14	53	3	Hjerner	V 9	140	-13,0	13,0	8	59	23	4	Hjerner	N 9	50	-16,0	16,0	21	54	16	4	Hjerner	S 9	50	-15,0	15,0
15	8	60	3	NT	V11	660	-12,0	12,0	8	59	23	4	Hjerner	N12	480	-1,0	1,0	28	34	51	3	NT	N 7	200	-20,0	20,0	21	30	17	4	Hjerner	N 9	50	-16,0	16,0	27	14	34	4	Hjerner	S 9	50	-15,0	15,0
9	1	15	3	NT	V11	660	-12,0	12,0	14	62	58	5	Hjerner	N12	480	-1,0	1,0	14	62	58	3	Spar	S 7	200	-20,0	20,0	18	36	16	4	Hjerner	N 9	50	-16,0	16,0	17	36	60	4	Hjerner	D N 9	100	-18,0	18,0
30	11	49	3	NT	V11	660	-12,0	12,0	27	37	4	4	Hjerner	S11	450	-20,0	20,0	19	21	45	4	Spar	S 8	200	-20,0	20,0	5	33	50	4	Hjerner	N 9	50	-16,0	16,0	3	20	38	3	Spar	Ø 9	140	-22,0	22,0
1	18	61	3	NT	V11	660	-12,0	12,0	29	47	28	3	NT	S 9	400	-26,0	26,0	29	47	28	4	Spar	S 8	200	-20,0	20,0	2	63	31	4	Hjerner	D N 9	100	-25,0	25,0	19	8	27	3	Spar	Ø 9	140	-22,0	22,0
12	40	46	3	NT	V11	660	-12,0	12,0	32	10	39	3	NT	S 9	400	-26,0	26,0	4	6	7	5	Kløver	N 9	200	-20,0	20,0	6	38	2	4	Hjerner	N 8	100	-25,0	25,0	15	41	35	3	Spar	Ø 9	140	-22,0	22,0
13	35	12	3	NT	V11	660	-12,0	12,0	33	24	44	3	NT	S 9	400	-26,0	26,0	8	59	23	3	Ruter	S 6	300	-27,0	27,0	3	20	32	4	Ruter	S 8	100	-25,0	25,0	30	37	11	2	Spar	V10	170	-27,0	27,0
21	30	17	5	NT	V11	660	-12,0	12,0	30	11	49	3	NT	N 9	400	-26,0	26,0	30	11	49	4	Spar	S 7	300	-27,0	27,0	23	9	57	4	Ruter	S 8	100	-25,0	25,0	32	24	10	3	Spar	Ø10	170	-27,0	27,0
7	29	64	3	NT	V12	690	-31,0	31,0	9	1	15	3	NT	S 9	400	-26,0	26,0	27	37	4	3	NT	N 5	400	-30,0	30,0	24	27	54	4	Kløver	V10	130	-30,0	30,0	22	57	3						

SPILLSTENSILER NM Veteran, 03. august 2010

♠ 8 Mappen: **22(86)**
 ♥ K643 Runden: **22**
 ♦ A86 ØV (Ø)
 ♣ AT987

♠ J643
 ♥ AT5
 ♦ KQ43
 ♣ J6

♠ Q72
 ♥ QJ2
 ♦ JT75
 ♣ K53

♠ AKT95
 ♥ 987
 ♦ 92
 ♣ Q42

♠ JT4 Mappen: **23(87)**
 ♥ AK32 Runden: **22**
 ♦ Q853 A (S)
 ♣ A2

♠ A86
 ♥ T96
 ♦ J6
 ♣ KT954

♠ KQ9
 ♥ QJ8754
 ♦ 2
 ♣ QJ8

♠ 7532
 ♥
 ♦ AKT974
 ♣ 763

♠ 93 Mappen: **24(88)**
 ♥ AKQ987 Runden: **22**
 ♦ 6 I (V)
 ♣ 8643

♠ K872
 ♥ J6
 ♦ Q9732
 ♣ A9

♠ AQJ654
 ♥ T
 ♦ AJ4
 ♣ J52

♠ T
 ♥ 5432
 ♦ KT85
 ♣ KQT7

Bord	NS	ØV		NS	ØV	NS	ØV	Bord	NS	ØV		NS	ØV	Bord	NS	ØV		NS	ØV	NS	ØV			
26	42	47	3 Ruter	D V 7	500	32,0	-32,0	18	68	30	3 NT	N 10	630	32,0	-32,0	8	31	21	5 Hjerter	D N 11	650	31,0	-31,0	
10	27	19	3 Spar	S 10	170	29,9	-29,9	1	58	63	4 Spar	S 10	620	29,9	-29,9	19	56	67	5 Hjerter	D S 11	650	31,0	-31,0	
16	60	62	2 Spar	S 9	140	27,8	-27,8	2	18	35	3 NT	N 9	600	22,7	-22,7	3	38	64	5 Hjerter	N 11	450	28,0	-28,0	
30	14	37	1 NT	N 8	120	24,8	-24,8	14	2	66	3 NT	N 9	600	22,7	-22,7	6	50	20	5 Spar	Ø 10	50	23,0	-23,0	
5	1	32	1 NT	N 8	120	24,8	-24,8	23	10	3	3 NT	N 9	600	22,7	-22,7	16	60	62	5 Spar	Ø 10	50	23,0	-23,0	
15	46	5	2 Hjerter	N 8	110	12,4	-12,4	16	60	62	5 Ruter	N 11	600	22,7	-22,7	33	52	24	5 Spar	Ø 10	50	23,0	-23,0	
24	12	49	2 Kløver	N 9	110	12,4	-12,4	26	42	47	5 Ruter	N 11	600	22,7	-22,7	17	55	34	5 Spar	Ø 10	50	23,0	-23,0	
12	23	15	2 Spar	S 8	110	12,4	-12,4	20	40	36	5 Ruter	N 11	600	22,7	-22,7	30	14	37	5 Hjerter	N 10	50	18,0	-18,0	
28	45	48	2 Spar	S 8	110	12,4	-12,4	12	23	15	4 Hjerter	D Ø 8	500	15,5	-15,5	7	25	7	5 Hjerter	D S 10	100	12,0	-12,0	
18	68	30	2 Spar	S 8	110	12,4	-12,4	27	11	16	4 Hjerter	D Ø 9	200	12,4	-12,4	15	46	5	5 Hjerter	D N 10	100	12,0	-12,0	
23	10	3	2 Spar	S 8	110	12,4	-12,4	33	52	24	4 Hjerter	D Ø 9	200	12,4	-12,4	14	2	66	5 Hjerter	D N 10	100	12,0	-12,0	
1	58	63	2 Spar	S 8	110	12,4	-12,4	29	26	53	1 NT	N 10	180	9,3	-9,3	4	33	17	5 Hjerter	D S 10	100	12,0	-12,0	
9	59	61	3 Kløver	N 9	110	12,4	-12,4	30	14	37	60%-60%			6,4	6,4	1	58	63	5 Hjerter	D N 10	100	12,0	-12,0	
3	38	64	3 Kløver	N 9	110	12,4	-12,4	6	50	20	3 Ruter	N 11	150	4,1	-4,1	10	27	19	4 Spar	Ø 10	420	-1,0	1,0	
11	41	6	3 Kløver	N 9	110	12,4	-12,4	11	41	6	4 Ruter	N 11	150	4,1	-4,1	24	12	49	4 Spar	Ø 10	420	-1,0	1,0	
25	44	54	1 NT	Ø 6	100	1,0	-1,0	19	56	67	4 Ruter	N 11	150	4,1	-4,1	9	59	61	4 Spar	Ø 10	420	-1,0	1,0	
17	55	34	0 Not played	0		0,0	0,0	22	65	9	4 Ruter	N 11	150	4,1	-4,1	27	11	16	4 Spar	Ø 10	420	-1,0	1,0	
29	26	53	1 NT	N 7	90	-1,0	1,0	25	44	54	3 Ruter	N 10	130	-6,2	6,2	31	51	28	4 Spar	Ø 10	420	-1,0	1,0	
2	18	35	Pass			-7,2	7,2	8	31	21	3 Ruter	N 10	130	-6,2	6,2	23	10	3	4 Spar	Ø 10	420	-1,0	1,0	
22	65	9	Pass			-7,2	7,2	3	38	64	3 Ruter	N 10	130	-6,2	6,2	11	41	6	4 Spar	Ø 10	420	-1,0	1,0	
6	50	20	Pass			-7,2	7,2	13	29	4	4 Ruter	N 10	130	-6,2	6,2	13	29	4	4 Spar	Ø 10	420	-1,0	1,0	
14	2	66	Pass			-7,2	7,2	15	46	5	4 Ruter	N 10	130	-6,2	6,2	26	42	47	4 Spar	Ø 11	450	-19,0	19,0	
20	40	36	Pass			-7,2	7,2	32	57	39	4 Ruter	N 10	130	-6,2	6,2	2	18	35	4 Spar	Ø 11	450	-19,0	19,0	
19	56	67	2 Spar	S 7		50	-19,6	19,6	4	33	17	2 Spar	S 8	110	-13,4	13,4	22	65	9	4 Spar	Ø 11	450	-19,0	19,0
8	31	21	2 Spar	S 7		50	-19,6	19,6	21	43	22	2 Spar	N 7	100	-19,6	19,6	28	45	48	4 Spar	Ø 11	450	-19,0	19,0
31	51	28	2 Spar	S 7		50	-19,6	19,6	28	45	48	5 Ruter	N 10	100	-19,6	19,6	5	1	32	4 Spar	Ø 11	450	-19,0	19,0
4	33	17	2 Spar	S 7		50	-19,6	19,6	7	25	7	5 Ruter	N 10	100	-19,6	19,6	21	43	22	4 Spar	Ø 11	450	-19,0	19,0
21	43	22	2 Spar	S 7		50	-19,6	19,6	9	59	61	5 Ruter	N 10	100	-19,6	19,6	25	44	54	4 Spar	Ø 11	450	-19,0	19,0
27	11	16	2 Spar	S 7		50	-19,6	19,6	24	12	49	5 Ruter	S 10	100	-19,6	19,6	32	57	39	4 Spar	Ø 11	450	-19,0	19,0
13	29	4	3 NT	N 8		50	-19,6	19,6	17	55	34	3 Hjerter	Ø 9	140	-25,8	25,8	29	26	53	4 Spar	Ø 11	450	-19,0	19,0
7	25	7	1 NT	Ø 7		90	-27,8	27,8	5	1	32	5 Ruter	D N 10	200	-28,9	28,9	12	23	15	5 Spar	Ø 11	450	-19,0	19,0
32	57	39	3 Hjerter	N 7		100	-29,9	29,9	10	27	19	5 Ruter	D N 10	200	-28,9	28,9	20	40	36	5 Spar	D Ø 11	650	-30,0	30,0
33	52	24	3 Hjerter	N 6		150	-32,0	32,0	31	51	28	3 Hjerter	D Ø 9	730	-32,0	32,0	18	68	30	4 Spar	D Ø 11	690	-32,0	32,0
34	8	13	WO						34	8	13	WO					34	8	13	WO				