

# SPILLSTENSILER

Mappnr: 1(1)  
Rundenr: 1

Nord / Ingen

♠ T843  
♥ 9  
♦ AQ5432  
♣ KJ

♠ KQ76  
♥ QT65  
♦ T8  
♣ T87

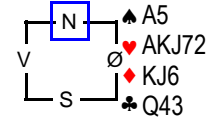

♠ J92  
♥ 843  
♦ 97  
♣ A9652

Bord	NS	ØV		NS	ØV	NS	ØV
14	27	28	2 NT	V 11	210	334,0	-334,0
26	51	52	3 NT	V 9	400	157,0	-157,0
29	57	58	3 NT	Ø 9	400	157,0	-157,0
34	67	68	4 Hjerter	Ø 10	420	119,0	-119,0
2	3	4	3 NT	Ø 10	430	114,0	-114,0
18	35	36	3 NT	Ø 10	430	114,0	-114,0
36	71	72	3 NT	Ø 11	460	74,0	-74,0
20	39	40	3 NT	V 11	460	74,0	-74,0
45	89	90	3 NT	Ø 11	460	74,0	-74,0
12	23	24	3 NT	V 11	460	74,0	-74,0
47	93	94	3 NT	Ø 11	460	74,0	-74,0
44	87	88	3 NT	Ø 11	460	74,0	-74,0
31	61	62	3 NT	Ø 11	460	74,0	-74,0
17	33	34	3 NT	Ø 11	460	74,0	-74,0
7	13	14	3 NT	Ø 11	460	74,0	-74,0
1	1	2	3 NT	Ø 11	460	74,0	-74,0
8	15	16	3 NT	Ø 11	460	74,0	-74,0
9	17	18	3 NT	Ø 11	460	74,0	-74,0
23	45	46	3 NT	Ø 12	490	33,0	-33,0
46	91	92	3 NT	V 12	490	33,0	-33,0
40	79	80	3 NT	Ø 12	490	33,0	-33,0
28	55	56	3 NT	Ø 12	490	33,0	-33,0
4	7	8	3 NT	Ø 12	490	33,0	-33,0
21	41	42	3 NT	Ø 12	490	33,0	-33,0
38	75	76	3 NT	Ø 12	490	33,0	-33,0
42	83	84	3 NT	Ø 12	490	33,0	-33,0
15	29	30	3 NT	Ø 12	490	33,0	-33,0
37	73	74	3 NT	Ø 12	490	33,0	-33,0
16	31	32	3 NT	Ø 12	490	33,0	-33,0
33	65	66	3 NT	Ø 12	490	33,0	-33,0
13	25	26	3 NT	Ø 12	490	33,0	-33,0
32	63	64	3 NT	Ø 12	490	33,0	-33,0
5	9	10	3 NT	Ø 12	490	33,0	-33,0
22	43	44	3 NT	Ø 12	490	33,0	-33,0
10	19	20	3 NT	V 12	490	33,0	-33,0
35	69	70	3 NT	Ø 12	490	33,0	-33,0
41	81	82	3 NT	Ø 12	490	33,0	-33,0
27	53	54	3 NT	Ø 12	490	33,0	-33,0
25	49	50	3 NT	Ø 12	490	33,0	-33,0
19	37	38	3 NT	Ø 13	520	-11,0	11,0
24	47	48	3 NT	Ø 13	520	-11,0	11,0
30	59	60	6 Ruter	V 12	920	-409,0	409,0
43	85	86	6 Ruter	V 12	920	-409,0	409,0
3	5	6	6 Ruter	V 12	920	-409,0	409,0
11	21	22	6 Ruter	V 12	920	-409,0	409,0
6	11	12	6 NT	Ø 12	990	-459,0	459,0
39	77	78	6 NT	Ø 12	990	-459,0	459,0

# IMP, 05. august 2010

Mappnr: 2(2)  
Rundenr: 1

Øst / N/S

♠ A8432  
♥ AT2  
♦ A87  
♣ KJ

♠ J7  
♥ KJ87  
♦ T942  
♣ T94

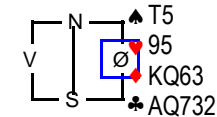

♠ KQ96  
♥ Q643  
♦ J5  
♣ 865

Bord	NS	ØV		NS	ØV	NS	ØV
27	53	54	4 Spar	V 8	100	476,0	-476,0
5	9	10	4 Spar	V 9	50	434,0	-434,0
16	31	32	5 Ruter	V 10	50	434,0	-434,0
20	39	40	1 NT	Ø 10	180	236,0	-236,0
6	11	12	2 NT	V 10	180	236,0	-236,0
40	79	80	1 NT	Ø 11	210	224,0	-224,0
8	15	16	3 NT	V 9	400	0,0	0,0
3	5	6	5 Kløver	Ø 11	400	0,0	0,0
46	91	92	3 NT	V 10	430	-42,0	42,0
26	51	52	3 NT	V 10	430	-42,0	42,0
22	43	44	3 NT	V 10	430	-42,0	42,0
21	41	42	3 NT	Ø 10	430	-42,0	42,0
44	87	88	3 NT	V 10	430	-42,0	42,0
38	75	76	3 NT	V 10	430	-42,0	42,0
37	73	74	3 NT	Ø 10	430	-42,0	42,0
29	57	58	3 NT	Ø 10	430	-42,0	42,0
39	77	78	3 NT	V 10	430	-42,0	42,0
24	47	48	3 NT	V 10	430	-42,0	42,0
14	27	28	3 NT	V 10	430	-42,0	42,0
36	71	72	3 NT	V 10	430	-42,0	42,0
28	55	56	3 NT	Ø 10	430	-42,0	42,0
25	49	50	3 NT	V 10	430	-42,0	42,0
30	59	60	3 NT	V 10	430	-42,0	42,0
42	83	84	3 NT	Ø 10	430	-42,0	42,0
31	61	62	3 NT	V 10	430	-42,0	42,0
18	35	36	3 NT	V 10	430	-42,0	42,0
34	67	68	3 NT	Ø 10	430	-42,0	42,0
19	37	38	3 NT	V 10	430	-42,0	42,0
32	63	64	3 NT	Ø 10	430	-42,0	42,0
1	1	2	3 NT	V 10	430	-42,0	42,0
17	33	34	3 NT	Ø 10	430	-42,0	42,0
23	45	46	3 NT	V 10	430	-42,0	42,0
47	93	94	3 NT	Ø 10	430	-42,0	42,0
41	81	82	3 NT	V 10	430	-42,0	42,0
2	3	4	3 NT	V 10	430	-42,0	42,0
10	19	20	3 NT	V 10	430	-42,0	42,0
4	7	8	3 NT	Ø 10	430	-42,0	42,0
7	13	14	3 NT	V 10	430	-42,0	42,0
35	69	70	4 NT	Ø 10	430	-42,0	42,0
11	21	22	3 NT	V 11	460	-87,0	87,0
33	65	66	3 NT	V 11	460	-87,0	87,0
43	85	86	3 NT	V 11	460	-87,0	87,0
9	17	18	3 NT	Ø 11	460	-87,0	87,0
13	25	26	3 NT	V 11	460	-87,0	87,0
12	23	24	3 NT	V 11	460	-87,0	87,0
15	29	30	3 NT	Ø 11	460	-87,0	87,0
45	89	90	3 NT	V 12	490	-129,0	129,0

# SPILLSTENSILER

Mappenr: **3(3)**  
Rundenr: **1**

Syd / Ø/V

♠ AQ  
♥ AJT54  
♦ 543  
♣ 863

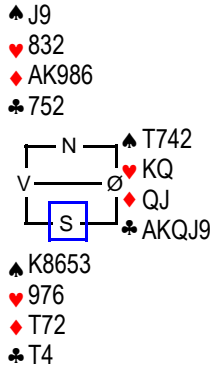

Bord	NS	ØV	NS	ØV	NS	ØV
19	37	38	6 NT D	V 8	1100	746,0 -746,0
4	7	8	6 NT D	V 8	1100	746,0 -746,0
15	29	30	6 NT D	V 8	1100	746,0 -746,0
5	9	10	6 NT D	V 10	500	543,0 -543,0
21	41	42	6 NT D	V 10	500	543,0 -543,0
6	11	12	6 NT D	V 10	500	543,0 -543,0
24	47	48	3 NT	V 8	100	384,0 -384,0
27	53	54	3 NT	Ø 8	100	384,0 -384,0
42	83	84	6 Hjerter	V 11	100	384,0 -384,0
1	1	2	6 Kløver	Ø 11	100	384,0 -384,0
34	67	68	3 Hjerter	V 11	200	216,0 -216,0
45	89	90	3 Hjerter	V 11	200	216,0 -216,0
16	31	32	3 Hjerter	V 11	200	216,0 -216,0
7	13	14	3 Hjerter	V 11	200	216,0 -216,0
30	59	60	5 Kløver	Ø 11	600	-109,0 109,0
36	71	72	4 Hjerter	V 10	620	-142,0 142,0
2	3	4	3 NT	V 10	630	-146,0 146,0
22	43	44	4 NT	V 10	630	-146,0 146,0
35	69	70	3 NT	Ø 11	660	-186,0 186,0
25	49	50	3 NT	Ø 11	660	-186,0 186,0
33	65	66	3 NT	Ø 11	660	-186,0 186,0
10	19	20	4 Hjerter	V 11	650	-186,0 186,0
32	63	64	4 Hjerter	V 11	650	-186,0 186,0
41	81	82	4 Hjerter	V 11	650	-186,0 186,0
46	91	92	4 Hjerter	V 11	650	-186,0 186,0
43	85	86	4 Hjerter	V 11	650	-186,0 186,0
38	75	76	4 Hjerter	V 11	650	-186,0 186,0
11	21	22	4 Hjerter	V 11	650	-186,0 186,0
29	57	58	4 Hjerter	V 11	650	-186,0 186,0
17	33	34	4 Hjerter	Ø 11	650	-186,0 186,0
20	39	40	4 Hjerter	V 11	650	-186,0 186,0
18	35	36	4 Hjerter	V 11	650	-186,0 186,0
44	87	88	4 Hjerter	V 11	650	-186,0 186,0
37	73	74	5 Hjerter	V 11	650	-186,0 186,0
39	77	78	5 Hjerter	V 11	650	-186,0 186,0
12	23	24	5 Hjerter	V 11	650	-186,0 186,0
23	45	46	5 Hjerter	V 11	650	-186,0 186,0
26	51	52	3 NT	V 12	690	-219,0 219,0
47	93	94	3 NT	V 12	690	-219,0 219,0
9	17	18	3 NT	V 12	690	-219,0 219,0
31	61	62	3 NT	Ø 12	690	-219,0 219,0
28	55	56	3 NT	V 12	690	-219,0 219,0
13	25	26	3 NT	V 12	690	-219,0 219,0
40	79	80	3 NT	V 12	690	-219,0 219,0
3	5	6	4 NT	V 12	690	-219,0 219,0
8	15	16	4 NT	V 12	690	-219,0 219,0
14	27	28	4 NT	Ø 12	690	-219,0 219,0

# IMP, 05. august 2010

Mappenr: **4(4)**  
Rundenr: **2**

Vest / Alle

♠ J  
♥ QT93  
♦ AKQ72  
♣ 872

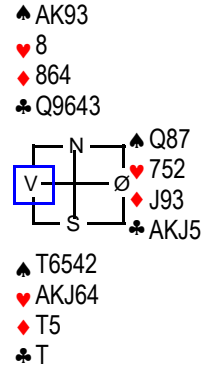

Bord	NS	ØV	NS	ØV	NS	ØV
21	43	41	3 Kløver D	Ø 8	200	347,0 -347,0
24	46	48	3 Kløver	Ø 7	200	347,0 -347,0
38	74	76	2 Spar	N 9	140	285,0 -285,0
1	3	1	3 Spar	N 9	140	285,0 -285,0
40	78	80	3 Spar	N 9	140	285,0 -285,0
35	71	69	3 Spar	N 9	140	285,0 -285,0
15	31	29	3 Spar	N 9	140	285,0 -285,0
19	39	37	3 Spar	S 9	140	285,0 -285,0
12	22	24	2 Hjerter	S 8	110	259,0 -259,0
41	83	81	2 Hjerter	Ø 7	100	253,0 -253,0
3	7	5	3 Kløver	V 8	100	253,0 -253,0
43	87	85	3 NT	Ø 8	100	253,0 -253,0
16	30	32	2 Hjerter	S 7	100	58,0 -58,0
34	66	68	3 Spar	N 8	100	58,0 -58,0
45	91	89	3 Spar	N 8	100	58,0 -58,0
4	6	8	3 Spar	S 8	100	58,0 -58,0
31	63	61	3 Ruter	V 9	110	45,0 -45,0
9	19	17	3 Ruter	V 9	110	45,0 -45,0
2	2	4	3 Ruter	V 9	110	45,0 -45,0
14	26	28	3 Ruter	Ø 9	110	45,0 -45,0
10	18	20	3 Ruter	V 9	110	45,0 -45,0
5	11	9	3 Ruter	V 9	110	45,0 -45,0
26	50	52	1 NT	Ø 8	120	30,0 -30,0
11	23	21	2 NT	Ø 8	120	30,0 -30,0
20	38	40	2 NT	Ø 8	120	30,0 -30,0
23	47	45	2 NT	Ø 8	120	30,0 -30,0
47	90	94	2 NT	Ø 8	120	30,0 -30,0
37	75	73	2 NT	Ø 8	120	30,0 -30,0
39	79	77	2 NT	V 8	120	30,0 -30,0
6	10	12	2 NT	Ø 8	120	30,0 -30,0
8	14	16	1 NT	Ø 10	180	-38,0 38,0
13	27	25	2 NT	V 10	180	-38,0 38,0
32	62	64	2 Hjerter	S 6	200	-57,0 57,0
30	58	60	2 Hjerter	S 6	200	-57,0 57,0
46	93	92	2 Spar D	N 7	200	-57,0 57,0
18	34	36	4 Spar D	N 9	200	-57,0 57,0
33	67	65	4 Spar D	N 9	200	-57,0 57,0
29	59	57	4 Spar D	N 9	200	-57,0 57,0
27	55	53	2 Hjerter D	S 6	500	-332,0 332,0
28	54	56	3 NT	Ø 9	600	-396,0 396,0
36	70	72	3 NT	V 9	600	-396,0 396,0
44	86	88	3 NT	Ø 9	600	-396,0 396,0
7	15	13	3 NT	Ø 9	600	-396,0 396,0
22	42	44	3 NT	Ø 10	630	-432,0 432,0
17	35	33	3 NT	Ø 10	630	-432,0 432,0
42	82	84	3 Kløver D	Ø 9	670	-445,0 445,0
25	51	49	4 Spar D	S 7	800	-521,0 521,0

# SPILLSTENSILER

Mappenr: **5(5)**  
Rundenr: **2**

Nord / N/S

- ♠ 94
- ♥ AKT93
- ♦ J65
- ♣ QJ6

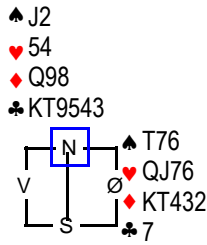

- ♠ AKQ853
- ♥ 82
- ♦ A7
- ♣ A82

Bord	NS	ØV	NS	ØV	NS	ØV
21	43	41	4 Spar D	S 10	790	480,0 -480,0
42	82	84	4 Spar	S 11	650	398,0 -398,0
24	46	48	4 Spar	S 11	650	398,0 -398,0
6	10	12	4 Spar	S 10	620	365,0 -365,0
22	42	44	4 Spar	S 10	620	365,0 -365,0
46	93	92	4 Spar	S 10	620	365,0 -365,0
27	55	53	4 Spar	S 10	620	365,0 -365,0
29	59	57	5 Hjerter D	V 8	500	270,0 -270,0
45	91	89	5 Hjerter D	V 8	500	270,0 -270,0
47	90	94	5 Hjerter D	V 8	500	270,0 -270,0
5	11	9	5 Hjerter D	V 8	500	270,0 -270,0
18	34	36	5 Hjerter D	V 8	500	270,0 -270,0
1	3	1	5 Hjerter D	V 8	500	270,0 -270,0
11	23	21	4 Hjerter D	V 8	300	77,0 -77,0
9	19	17	3 Spar	S 11	200	-24,0 24,0
36	70	72	2 Spar	S 10	170	-62,0 62,0
37	75	73	3 Spar	S 10	170	-62,0 62,0
14	26	28	3 Spar	S 10	170	-62,0 62,0
12	22	24	3 Spar	S 10	170	-62,0 62,0
17	35	33	3 Spar	S 10	170	-62,0 62,0
33	67	65	3 Spar	S 10	170	-62,0 62,0
44	86	88	3 Spar	S 10	170	-62,0 62,0
13	27	25	3 Spar	S 10	170	-62,0 62,0
26	50	52	4 Hjerter	V 7	150	-92,0 92,0
31	63	61	5 Hjerter	V 8	150	-92,0 92,0
7	15	13	5 Hjerter	V 8	150	-92,0 92,0
20	38	40	3 Spar	S 9	140	-95,0 95,0
32	62	64	3 Spar	S 9	140	-95,0 95,0
35	71	69	3 Spar	S 9	140	-95,0 95,0
15	31	29	3 Spar	S 9	140	-95,0 95,0
3	7	5	3 Spar	S 9	140	-95,0 95,0
41	83	81	3 Spar	S 9	140	-95,0 95,0
38	74	76	3 Spar	S 9	140	-95,0 95,0
8	14	16	3 Spar	S 9	140	-95,0 95,0
10	18	20	3 Spar	S 9	140	-95,0 95,0
43	87	85	1 NT	S 8	120	-130,0 130,0
40	78	80	1 NT	S 8	120	-130,0 130,0
25	51	49	4 Hjerter	V 8	100	-144,0 144,0
19	39	37	4 Hjerter	V 8	100	-144,0 144,0
2	2	4	4 Hjerter	V 8	100	-144,0 144,0
30	58	60	3 Hjerter	V 8	50	-200,0 200,0
34	66	68	3 Hjerter	V 8	50	-200,0 200,0
16	30	32	4 Spar	S 9	100	-338,0 338,0
28	54	56	4 Spar	S 9	100	-338,0 338,0
23	47	45	4 Spar	S 9	100	-338,0 338,0
4	6	8	4 Spar	S 9	100	-338,0 338,0
39	79	77	4 Spar	S 9	100	-338,0 338,0

# IMP, 05. august 2010

Mappenr: **6(6)**  
Rundenr: **2**

Øst / Ø/V

- ♠ 3
- ♥ AK6432
- ♦ K863
- ♣ AK

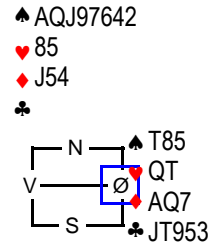

- ♠ K
- ♥ J97
- ♦ T92
- ♣ Q87642

Bord	NS	ØV	NS	ØV	NS	ØV
4	6	8	5 Kløver	Ø 9	200	520,0 -520,0
42	82	84	4 Spar	N 9	50	360,0 -360,0
37	75	73	3 Spar D	N 8	100	309,0 -309,0
16	30	32	4 Spar	N 8	100	309,0 -309,0
40	78	80	4 Spar	N 8	100	309,0 -309,0
22	42	44	4 Spar	N 8	100	309,0 -309,0
23	47	45	4 Spar	N 8	100	309,0 -309,0
28	54	56	4 Spar	N 8	100	309,0 -309,0
11	23	21	4 Spar	N 8	100	309,0 -309,0
36	70	72	4 Spar	N 8	100	309,0 -309,0
34	66	68	4 Spar	N 8	100	309,0 -309,0
12	22	24	5 Spar D	N 10	100	309,0 -309,0
15	31	29	4 Spar	N 7	150	262,0 -262,0
45	91	89	5 Spar	N 8	150	262,0 -262,0
43	87	85	4 Spar D	N 8	300	133,0 -133,0
46	93	92	4 Spar D	N 8	300	133,0 -133,0
39	79	77	4 Spar D	N 8	300	133,0 -133,0
24	46	48	4 Spar D	N 8	300	133,0 -133,0
25	51	49	4 Spar D	N 8	300	133,0 -133,0
35	71	69	4 Spar D	N 8	300	133,0 -133,0
26	50	52	4 Spar D	N 8	300	133,0 -133,0
2	2	4	4 Spar D	N 8	300	133,0 -133,0
30	58	60	4 Spar D	N 8	300	133,0 -133,0
17	35	33	4 Spar D	N 8	300	133,0 -133,0
47	90	94	4 Spar D	N 8	300	133,0 -133,0
10	18	20	4 Spar D	N 8	300	133,0 -133,0
20	38	40	4 Spar D	N 7	500	-51,0 51,0
31	63	61	5 Spar D	N 8	500	-51,0 51,0
21	43	41	5 Spar D	N 8	500	-51,0 51,0
3	7	5	5 Spar D	N 8	500	-51,0 51,0
32	62	64	5 Ruter	V 12	620	-159,0 159,0
7	15	13	4 Hjerter	V 12	680	-206,0 206,0
18	34	36	5 Hjerter	V 12	680	-206,0 206,0
38	74	76	5 Hjerter	V 12	680	-206,0 206,0
8	14	16	5 Hjerter	V 12	680	-206,0 206,0
14	26	28	5 Hjerter	V 12	680	-206,0 206,0
44	86	88	5 Hjerter	V 12	680	-206,0 206,0
29	59	57	5 Hjerter	V 12	680	-206,0 206,0
13	27	25	5 Hjerter	V 13	710	-229,0 229,0
1	3	1	5 Hjerter	V 13	710	-229,0 229,0
19	39	37	6 Spar D	N 8	800	-293,0 293,0
5	11	9	6 Ruter	V 12	1370	-555,0 555,0
9	19	17	6 Ruter	V 12	1370	-555,0 555,0
27	55	53	6 Hjerter	V 12	1430	-601,0 601,0
41	83	81	6 Hjerter	V 12	1430	-601,0 601,0
6	10	12	6 Hjerter	V 13	1460	-611,0 611,0
33	67	65	6 Hjerter	V 13	1460	-611,0 611,0

# SPILLSTENSILER

Mappennr: 7(7)  
Rundenr: 3

Syd / Alle

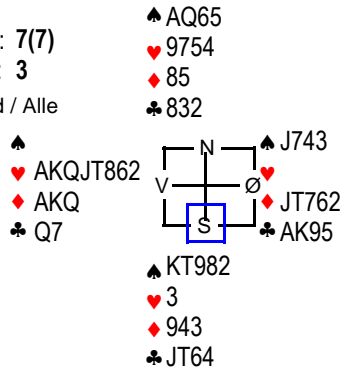

Bord	NS	ØV			NS	ØV	NS	ØV
25	80	57	7 NT D	V 8	1400	972,0	-972,0	
24	28	79	4 Hjerter	V 13	710	535,0	-535,0	
32	69	63	4 Hjerter	Ø 13	710	535,0	-535,0	
3	78	22	4 Hjerter	V 13	710	535,0	-535,0	
15	76	92	4 Hjerter	Ø 13	710	535,0	-535,0	
38	68	65	4 Hjerter	V 13	710	535,0	-535,0	
19	44	34	5 Hjerter	V 13	710	535,0	-535,0	
9	26	11	6 Ruter	Ø 13	1390	84,0	-84,0	
37	17	55	6 Hjerter	V 13	1460	15,0	-15,0	
20	16	89	6 Hjerter	V 13	1460	15,0	-15,0	
47	54	10	6 Hjerter	V 13	1460	15,0	-15,0	
7	41	1	6 Hjerter	V 13	1460	15,0	-15,0	
29	33	87	6 Hjerter	Ø 13	1460	15,0	-15,0	
13	20	46	6 Hjerter	V 13	1460	15,0	-15,0	
26	3	51	6 Hjerter	V 13	1460	15,0	-15,0	
10	66	67	6 Hjerter	V 13	1460	15,0	-15,0	
34	49	75	6 Hjerter	V 13	1460	15,0	-15,0	
35	81	45	6 Hjerter	V 13	1460	15,0	-15,0	
46	40	8	6 Hjerter	V 13	1460	15,0	-15,0	
43	32	38	6 Hjerter	V 13	1460	15,0	-15,0	
44	30	21	6 Hjerter	V 13	1460	15,0	-15,0	
27	71	35	6 Hjerter	V 13	1460	15,0	-15,0	
16	70	82	6 Hjerter	V 13	1460	15,0	-15,0	
40	48	84	6 Hjerter	V 13	1460	15,0	-15,0	
1	9	53	6 Hjerter	V 13	1460	15,0	-15,0	
17	74	62	6 Hjerter	V 13	1460	15,0	-15,0	
21	36	72	6 Hjerter	V 13	1460	15,0	-15,0	
39	12	25	6 Hjerter	V 13	1460	15,0	-15,0	
33	73	91	6 Hjerter	V 13	1460	15,0	-15,0	
6	60	31	6 Hjerter	V 13	1460	15,0	-15,0	
30	43	93	6 Hjerter	Ø 13	1460	15,0	-15,0	
41	2	42	6 Hjerter	V 13	1460	15,0	-15,0	
45	85	77	6 Hjerter	V 13	1460	15,0	-15,0	
36	14	23	6 Hjerter	V 13	1460	15,0	-15,0	
31	61	19	6 Hjerter	V 13	1460	15,0	-15,0	
28	90	15	6 Hjerter	V 13	1460	15,0	-15,0	
11	56	18	6 Hjerter	V 13	1460	15,0	-15,0	
2	7	39	6 Hjerter	V 13	1460	15,0	-15,0	
14	64	50	7 Ruter	Ø 13	2140	-476,0	476,0	
8	83	47	7 Hjerter	V 13	2210	-530,0	530,0	
12	24	13	7 Hjerter	V 13	2210	-530,0	530,0	
5	29	6	7 Hjerter	V 13	2210	-530,0	530,0	
22	52	4	7 Hjerter	V 13	2210	-530,0	530,0	
42	5	59	7 Hjerter	V 13	2210	-530,0	530,0	
23	58	27	7 Hjerter	V 13	2210	-530,0	530,0	
4	86	37	7 Hjerter	Ø 13	2210	-530,0	530,0	
18	94	88	7 Hjerter	Ø 13	2210	-530,0	530,0	

# IMP, 05. august 2010

Mappennr: 8(8)  
Rundenr: 3

Vest / Ingen

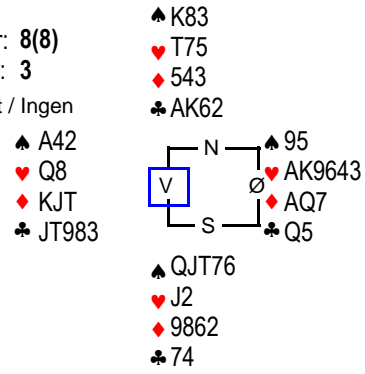

Bord	NS	ØV			NS	ØV	NS	ØV
32	69	63	5 Hjerter	Ø 10	50	460,0	-460,0	
27	71	35	3 Hjerter	Ø 10	170	268,0	-268,0	
47	54	10	3 NT	Ø 10	430	-12,0	12,0	
17	74	62	3 NT	V 10	430	-12,0	12,0	
29	33	87	3 NT	Ø 10	430	-12,0	12,0	
46	40	8	3 NT	Ø 10	430	-12,0	12,0	
28	90	15	4 Hjerter	Ø 10	420	-12,0	12,0	
7	41	1	4 Hjerter	Ø 10	420	-12,0	12,0	
5	29	6	4 Hjerter	Ø 10	420	-12,0	12,0	
20	16	89	4 Hjerter	Ø 10	420	-12,0	12,0	
23	58	27	4 Hjerter	Ø 10	420	-12,0	12,0	
24	28	79	4 Hjerter	Ø 10	420	-12,0	12,0	
43	32	38	4 Hjerter	Ø 10	420	-12,0	12,0	
8	83	47	4 Hjerter	Ø 10	420	-12,0	12,0	
19	44	34	4 Hjerter	Ø 10	420	-12,0	12,0	
31	61	19	4 Hjerter	Ø 10	420	-12,0	12,0	
15	76	92	4 Hjerter	Ø 10	420	-12,0	12,0	
34	49	75	4 Hjerter	Ø 10	420	-12,0	12,0	
35	81	45	4 Hjerter	Ø 10	420	-12,0	12,0	
25	80	57	4 Hjerter	Ø 10	420	-12,0	12,0	
42	5	59	4 Hjerter	Ø 10	420	-12,0	12,0	
18	94	88	4 Hjerter	Ø 10	420	-12,0	12,0	
33	73	91	4 Hjerter	Ø 10	420	-12,0	12,0	
4	86	37	4 Hjerter	Ø 10	420	-12,0	12,0	
26	3	51	4 Hjerter	Ø 10	420	-12,0	12,0	
1	9	53	4 Hjerter	Ø 10	420	-12,0	12,0	
14	64	50	4 Hjerter	Ø 10	420	-12,0	12,0	
39	12	25	4 Hjerter	Ø 10	420	-12,0	12,0	
36	14	23	4 Hjerter	Ø 10	420	-12,0	12,0	
22	52	4	4 Hjerter	Ø 10	420	-12,0	12,0	
37	17	55	4 Hjerter	Ø 10	420	-12,0	12,0	
3	78	22	4 Hjerter	Ø 10	420	-12,0	12,0	
13	20	46	4 Hjerter	Ø 10	420	-12,0	12,0	
16	70	82	4 Hjerter	Ø 10	420	-12,0	12,0	
12	24	13	4 Hjerter	Ø 10	420	-12,0	12,0	
45	85	77	4 Hjerter	Ø 10	420	-12,0	12,0	
2	7	39	4 Hjerter	Ø 10	420	-12,0	12,0	
11	56	18	4 Hjerter	Ø 10	420	-12,0	12,0	
9	26	11	4 Hjerter	Ø 10	420	-12,0	12,0	
10	66	67	4 Hjerter	Ø 10	420	-12,0	12,0	
41	2	42	4 Hjerter	Ø 10	420	-12,0	12,0	
44	30	21	4 Hjerter	Ø 10	420	-12,0	12,0	
38	68	65	4 Hjerter	Ø 10	420	-12,0	12,0	
6	60	31	3 NT	V 11	460	-59,0	59,0	
40	48	84	3 NT	V 11	460	-59,0	59,0	
21	36	72	3 NT	V 11	460	-59,0	59,0	
30	43	93	4 Hjerter	Ø 11	450	-59,0	59,0	

# SPILLSTENSILER

Mappenr: **9(9)**  
Rundenr: **3**

Nord / ØV

- ♠ 63
- ♥ QJ532
- ♦ 64
- ♣ K843

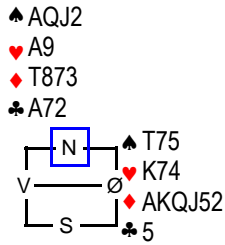

- ♠ K984
- ♥ T86
- ♦ 9
- ♣ QJT96

Bord	NS	ØV	NS	ØV	NS	ØV
10	66	67	4 Spar	S 12	480	375,0 -375,0
8	83	47	4 Spar	N 11	450	338,0 -338,0
5	29	6	4 Hjerter	N 10	420	318,0 -318,0
35	81	45	4 Spar	N 10	420	318,0 -318,0
7	41	1	4 Spar	N 10	420	318,0 -318,0
4	86	37	4 Spar	N 10	420	318,0 -318,0
3	78	22	4 Spar	N 10	420	318,0 -318,0
42	5	59	4 Spar	N 10	420	318,0 -318,0
45	85	77	2 Spar	S 11	200	93,0 -93,0
21	36	72	3 Spar	N 11	200	93,0 -93,0
34	49	75	2 Spar	N 10	170	59,0 -59,0
1	9	53	2 Spar	S 10	170	59,0 -59,0
6	60	31	2 Spar	N 10	170	59,0 -59,0
24	28	79	2 Spar	N 9	140	33,0 -33,0
13	20	46	2 Spar	N 9	140	33,0 -33,0
12	24	13	2 Spar	N 8	110	-7,0 7,0
19	44	34	3 Kløver	S 9	110	-7,0 7,0
9	26	11	3 Kløver	N 9	110	-7,0 7,0
26	3	51	3 Kløver	S 9	110	-7,0 7,0
11	56	18	3 Kløver	S 9	110	-7,0 7,0
17	74	62	3 Ruter	Ø 8	100	-30,0 30,0
25	80	57	1 NT	N 7	90	-37,0 37,0
37	17	55	1 NT	N 7	90	-37,0 37,0
20	16	89	1 NT	N 7	90	-37,0 37,0
41	2	42	1 NT	N 7	90	-37,0 37,0
15	76	92	1 NT	N 7	90	-37,0 37,0
33	73	91	1 NT	N 7	90	-37,0 37,0
46	40	8	1 NT	N 7	90	-37,0 37,0
22	52	4	1 NT	N 7	90	-37,0 37,0
16	70	82	1 NT	N 7	90	-37,0 37,0
27	71	35	1 NT	N 7	90	-37,0 37,0
23	58	27	1 NT	N 7	90	-37,0 37,0
38	68	65	1 NT	N 7	90	-37,0 37,0
28	90	15	1 NT	N 7	90	-37,0 37,0
30	43	93	1 NT	N 7	90	-37,0 37,0
2	7	39	1 NT	N 7	90	-37,0 37,0
14	64	50	1 NT	N 7	90	-37,0 37,0
36	14	23	1 NT	N 6	50	-199,0 199,0
44	30	21	4 Spar	N 9	50	-199,0 199,0
47	54	10	4 Spar	N 9	50	-199,0 199,0
31	61	19	4 Spar	N 9	50	-199,0 199,0
29	33	87	1 NT	Ø 7	90	-242,0 242,0
39	12	25	5 Kløver	S 9	100	-250,0 250,0
18	94	88	2 Hjerter	Ø 8	110	-256,0 256,0
32	69	63	2 Ruter	V 10	130	-283,0 283,0
43	32	38	3 Ruter	Ø 10	130	-283,0 283,0
40	48	84	3 Ruter	Ø 10	130	-283,0 283,0

# IMP, 05. august 2010

Mappenr: **10(10)**  
Rundenr: **4**

Øst / Alle

- ♠ J7643
- ♥ T432
- ♦ K93
- ♣ T

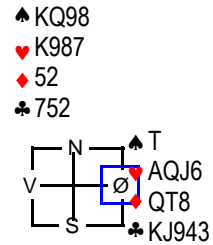

- ♠ A52
- ♥ 5
- ♦ AJ764
- ♣ AQ86

Bord	NS	ØV	NS	ØV	NS	ØV
39	69	59	2 NT D	S 8	690	500,0 -500,0
27	57	61	3 NT	N 10	630	466,0 -466,0
15	50	76	3 NT	S 9	600	445,0 -445,0
36	68	73	3 NT	S 9	600	445,0 -445,0
6	88	7	3 NT	S 9	600	445,0 -445,0
31	45	41	3 Kløver D	Ø 7	500	387,0 -387,0
29	12	83	3 Kløver	Ø 5	400	315,0 -315,0
41	30	5	1 NT D	Ø 6	200	125,0 -125,0
5	37	6	2 Hjerter D	Ø 7	200	125,0 -125,0
43	38	55	2 Kløver	Ø 6	200	125,0 -125,0
33	24	27	2 Kløver	Ø 6	200	125,0 -125,0
16	93	3	2 NT	Ø 6	200	125,0 -125,0
47	84	54	2 Spar	V 6	200	125,0 -125,0
35	89	2	1 NT	S 10	180	106,0 -106,0
34	42	63	2 NT	N 10	180	106,0 -106,0
9	65	16	1 NT	S 9	150	65,0 -65,0
45	8	21	1 NT	S 9	150	65,0 -65,0
32	92	94	1 NT	S 9	150	65,0 -65,0
37	80	67	2 NT	N 9	150	65,0 -65,0
46	48	10	2 NT	S 8	120	45,0 -45,0
25	40	26	2 Ruter	S 9	110	23,0 -23,0
21	1	25	3 Ruter	S 9	110	23,0 -23,0
7	60	56	2 Hjerter	Ø 7	100	9,0 -9,0
20	20	36	2 Hjerter	Ø 7	100	9,0 -9,0
19	34	74	1 NT	S 7	90	4,0 -4,0
42	32	19	1 NT	S 7	90	4,0 -4,0
12	18	47	2 Ruter	S 8	90	4,0 -4,0
24	11	70	2 Ruter	S 7	100	-190,0 190,0
10	66	91	2 Spar	N 7	100	-190,0 190,0
26	86	39	2 Spar	S 7	100	-190,0 190,0
18	28	71	3 Kløver	S 8	100	-190,0 190,0
3	78	31	3 NT	N 8	100	-190,0 190,0
38	77	35	3 NT	S 8	100	-190,0 190,0
17	33	23	3 NT	N 8	100	-190,0 190,0
30	62	79	3 NT	N 8	100	-190,0 190,0
2	22	9	3 Spar	N 8	100	-190,0 190,0
1	82	53	4 Spar	N 9	100	-190,0 190,0
8	64	43	1 Hjerter	Ø 8	110	-192,0 192,0
28	44	58	2 Hjerter	Ø 8	110	-192,0 192,0
40	14	51	2 Kløver	Ø 9	110	-192,0 192,0
4	46	13	1 Hjerter	Ø 9	140	-230,0 230,0
22	4	87	2 Hjerter	Ø 9	140	-230,0 230,0
13	72	81	2 Hjerter	Ø 9	140	-230,0 230,0
14	29	90	2 Ruter	S 6	200	-295,0 295,0
23	52	75	2 Ruter	N 6	200	-295,0 295,0
11	49	17	3 NT	S 7	200	-295,0 295,0
44	15	85	3 Ruter	S 7	200	-295,0 295,0

# SPILLSTENSILER

Mappenr: 11(11)  
Rundenr: 4

Syd / Ingen

- ♠ 832
- ♥ T43
- ♦ 752
- ♣ J976

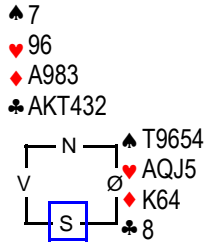

- ♠ AKQJ
- ♥ K872
- ♦ QJT
- ♣ Q5

Bord	NS	ØV	NS	ØV	NS	ØV
32	92	94	6 NT	S 12	990	548,0 -548,0
38	77	35	6 NT	S 12	990	548,0 -548,0
7	60	56	3 NT	S 12	490	213,0 -213,0
19	34	74	3 NT	N 12	490	213,0 -213,0
14	29	90	3 NT	S 11	460	185,0 -185,0
44	15	85	3 NT	S 11	460	185,0 -185,0
10	66	91	3 NT	S 11	460	185,0 -185,0
17	33	23	3 NT	N 11	460	185,0 -185,0
35	89	2	3 NT	S 11	460	185,0 -185,0
34	42	63	3 NT	N 11	460	185,0 -185,0
24	11	70	3 NT	S 11	460	185,0 -185,0
40	14	51	3 NT	S 11	460	185,0 -185,0
25	40	26	3 NT	S 11	460	185,0 -185,0
4	46	13	3 NT	S 11	460	185,0 -185,0
8	64	43	4 NT	S 11	460	185,0 -185,0
20	20	36	5 NT	S 11	460	185,0 -185,0
22	4	87	3 NT	S 10	430	143,0 -143,0
6	88	7	3 NT	S 10	430	143,0 -143,0
15	50	76	3 NT	N 10	430	143,0 -143,0
11	49	17	3 NT	S 10	430	143,0 -143,0
41	30	5	3 NT	S 10	430	143,0 -143,0
39	69	59	3 NT	S 10	430	143,0 -143,0
26	86	39	4 NT	S 10	430	143,0 -143,0
45	8	21	4 NT	S 10	430	143,0 -143,0
33	24	27	3 NT	S 9	400	115,0 -115,0
21	1	25	3 NT	S 9	400	115,0 -115,0
16	93	3	3 NT	S 9	400	115,0 -115,0
47	84	54	3 NT	S 9	400	115,0 -115,0
23	52	75	3 NT	S 9	400	115,0 -115,0
31	45	41	5 Kløver	N 11	400	115,0 -115,0
30	62	79	4 Hjerter	S 9	50	-311,0 311,0
27	57	61	4 NT	S 9	50	-311,0 311,0
2	22	9	6 Kløver	S 11	50	-311,0 311,0
3	78	31	6 Kløver	N 11	50	-311,0 311,0
9	65	16	6 Kløver	N 11	50	-311,0 311,0
5	37	6	6 Kløver	N 11	50	-311,0 311,0
37	80	67	6 Kløver	S 11	50	-311,0 311,0
18	28	71	6 Kløver	N 11	50	-311,0 311,0
12	18	47	6 Kløver	N 11	50	-311,0 311,0
29	12	83	6 NT	S 11	50	-311,0 311,0
28	44	58	6 NT	N 11	50	-311,0 311,0
43	38	55	6 NT	N 11	50	-311,0 311,0
36	68	73	6 Ruter	S 11	50	-311,0 311,0
1	82	53	6 NT	S 10	100	-357,0 357,0
46	48	10	6 NT	S 10	100	-357,0 357,0
13	72	81	6 NT	S 9	150	-393,0 393,0
42	32	19	6 NT	S 8	200	-426,0 426,0

# IMP, 05. august 2010

Mappenr: 12(12)  
Rundenr: 4

Vest / N/S

- ♠ QT854
- ♥ Q6
- ♦ AK75
- ♣ 65

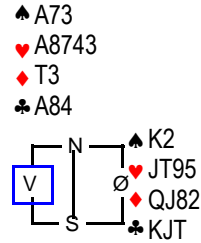

- ♠ J96
- ♥ K2
- ♦ 964
- ♣ Q9732

Bord	NS	ØV	NS	ØV	NS	ØV
43	38	55	2 NT D	Ø 6	300	437,0 -437,0
28	44	58	3 NT	Ø 5	200	362,0 -362,0
32	92	94	3 NT	Ø 6	150	320,0 -320,0
8	64	43	3 NT	Ø 6	150	320,0 -320,0
20	20	36	3 NT	Ø 6	150	320,0 -320,0
18	28	71	3 NT	Ø 6	150	320,0 -320,0
42	32	19	2 NT	Ø 6	100	278,0 -278,0
1	82	53	2 NT	Ø 6	100	278,0 -278,0
21	1	25	2 NT	Ø 6	100	278,0 -278,0
35	89	2	2 NT	Ø 6	100	278,0 -278,0
44	15	85	1 NT	Ø 6	50	223,0 -223,0
26	86	39	1 NT	Ø 6	50	223,0 -223,0
34	42	63	2 Spar	V 7	50	223,0 -223,0
10	66	91	3 Ruter	V 8	50	223,0 -223,0
24	11	70	Pass			183,0 -183,0
7	60	56	2 Hjerter	N 7	100	80,0 -80,0
6	88	7	2 Spar	V 8	110	79,0 -79,0
47	84	54	3 Ruter	V 9	110	79,0 -79,0
40	14	51	3 Ruter	V 9	110	79,0 -79,0
15	50	76	2 Spar	V 9	140	33,0 -33,0
3	78	31	3 Spar	V 9	140	33,0 -33,0
38	77	35	3 Spar	V 9	140	33,0 -33,0
19	34	74	3 Spar	V 9	140	33,0 -33,0
5	37	6	1 NT	Ø 9	150	32,0 -32,0
27	57	61	2 Spar	V 10	170	2,0 -2,0
11	49	17	1 NT	S 5	200	-28,0 28,0
33	24	27	2 Hjerter	N 6	200	-28,0 28,0
12	18	47	2 Hjerter	N 6	200	-28,0 28,0
23	52	75	2 Hjerter	N 6	200	-28,0 28,0
4	46	13	2 Hjerter	N 6	200	-28,0 28,0
36	68	73	1 NT	S 4	300	-130,0 130,0
2	22	9	1 NT	S 4	300	-130,0 130,0
37	80	67	1 NT	S 4	300	-130,0 130,0
45	8	21	2 Hjerter	N 5	300	-130,0 130,0
16	93	3	3 NT	Ø 9	400	-224,0 224,0
13	72	81	3 NT	Ø 10	430	-255,0 255,0
29	12	83	3 NT	Ø 10	430	-255,0 255,0
17	33	23	2 Hjerter D	N 6	500	-315,0 315,0
31	45	41	2 Hjerter D	N 6	500	-315,0 315,0
9	65	16	2 Hjerter D	N 6	500	-315,0 315,0
39	69	59	2 Hjerter D	N 6	500	-315,0 315,0
30	62	79	2 Hjerter D	N 6	500	-315,0 315,0
41	30	5	2 Hjerter D	N 6	500	-315,0 315,0
14	29	90	2 Hjerter D	N 6	500	-315,0 315,0
22	4	87	2 Hjerter D	N 6	500	-315,0 315,0
25	40	26	2 Hjerter D	N 6	500	-315,0 315,0
46	48	10	1 NT D	S 4	800	-520,0 520,0

# SPILLSTENSILER

Mappnr: 13(13)  
Rundenr: 5

Nord / Alle

♠ KT8765  
♥ 652  
♦ Q83  
♣ 2

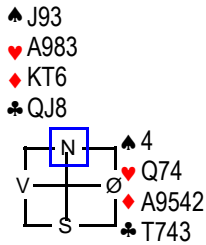

♠ AQ2  
♥ KJT  
♦ J7  
♣ AK965

Bord	NS	ØV		NS	ØV	NS	ØV
23	75	11	3 NT	S 12	690	60,0	-60,0
16	87	93	3 NT	S 12	690	60,0	-60,0
38	79	35	3 NT	S 12	690	60,0	-60,0
31	59	34	3 NT	S 12	690	60,0	-60,0
14	80	44	3 NT	S 12	690	60,0	-60,0
7	60	66	3 NT	S 12	690	60,0	-60,0
41	85	24	3 NT	S 12	690	60,0	-60,0
13	16	23	3 NT	S 12	690	60,0	-60,0
21	74	20	3 NT	S 12	690	60,0	-60,0
6	50	7	3 NT	S 12	690	60,0	-60,0
27	40	33	3 NT	S 12	690	60,0	-60,0
45	10	32	3 NT	S 12	690	60,0	-60,0
33	89	45	3 NT	S 11	660	14,0	-14,0
18	25	17	3 NT	S 11	660	14,0	-14,0
19	72	3	3 NT	S 11	660	14,0	-14,0
4	6	31	3 NT	S 11	660	14,0	-14,0
42	8	30	3 NT	S 11	660	14,0	-14,0
46	94	54	3 NT	S 11	660	14,0	-14,0
20	36	69	3 NT	N 11	660	14,0	-14,0
11	81	43	3 NT	S 11	660	14,0	-14,0
1	88	78	3 NT	S 11	660	14,0	-14,0
9	4	56	3 NT	S 11	660	14,0	-14,0
37	51	58	3 NT	S 11	660	14,0	-14,0
36	52	77	3 NT	S 11	660	14,0	-14,0
26	70	64	3 NT	N 11	660	14,0	-14,0
30	61	83	3 NT	S 11	660	14,0	-14,0
34	2	38	3 NT	S 11	660	14,0	-14,0
40	67	14	3 NT	S 11	660	14,0	-14,0
35	19	73	3 NT	N 11	660	14,0	-14,0
2	13	53	3 NT	S 11	660	14,0	-14,0
12	91	71	3 NT	S 11	660	14,0	-14,0
8	76	28	3 NT	S 11	660	14,0	-14,0
28	62	1	3 NT	N 11	660	14,0	-14,0
25	68	29	4 Hjerter	N 11	650	14,0	-14,0
24	65	39	5 Hjerter	S 11	650	14,0	-14,0
44	63	57	3 NT	S 10	630	-33,0	33,0
43	21	5	3 NT	S 10	630	-33,0	33,0
15	22	49	3 NT	S 10	630	-33,0	33,0
29	42	86	3 NT	S 10	630	-33,0	33,0
39	92	55	3 NT	S 10	630	-33,0	33,0
10	82	47	3 NT	S 10	630	-33,0	33,0
47	48	15	3 NT	S 10	630	-33,0	33,0
32	84	12	4 Hjerter	N 10	620	-33,0	33,0
3	9	90	4 Hjerter	N 10	620	-33,0	33,0
17	18	27	3 NT	S 9	600	-79,0	79,0
22	26	41	3 NT	N 9	600	-79,0	79,0
5	37	46	5 Kløver	N 10	100	-587,0	587,0

# IMP, 05. august 2010

Mappnr: 14(14)  
Rundenr: 5

Øst / Ingen

♠ A3  
♥ AQ82  
♦ 32  
♣ KJT53

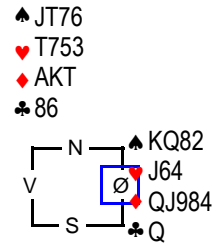

♠ 954  
♥ K9  
♦ 765  
♣ A9742

Bord	NS	ØV		NS	ØV	NS	ØV
22	26	41	4 Hjerter	V 8	100	400,0	-400,0
35	19	73	3 NT	V 8	50	349,0	-349,0
27	40	33	3 NT	Ø 8	50	349,0	-349,0
12	91	71	3 NT	V 8	50	349,0	-349,0
10	82	47	3 NT	V 8	50	349,0	-349,0
19	72	3	3 NT	V 8	50	349,0	-349,0
14	80	44	3 NT	V 8	50	349,0	-349,0
13	16	23	4 Hjerter	V 9	50	349,0	-349,0
20	36	69	1 Kløver	V 9	110	210,0	-210,0
41	85	24	1 NT	V 8	120	182,0	-182,0
6	50	7	2 Ruter	Ø 10	130	180,0	-180,0
38	79	35	2 Hjerter	V 9	140	167,0	-167,0
37	51	58	1 NT	V 9	150	162,0	-162,0
9	4	56	1 NT	Ø 9	150	162,0	-162,0
45	10	32	1 NT	V 10	180	126,0	-126,0
4	6	31	1 NT	Ø 10	180	126,0	-126,0
43	21	5	1 NT	V 10	180	126,0	-126,0
46	94	54	3 NT	V 9	400	-111,0	111,0
21	74	20	3 NT	V 9	400	-111,0	111,0
34	2	38	3 NT	Ø 9	400	-111,0	111,0
32	84	12	3 NT	Ø 9	400	-111,0	111,0
42	8	30	3 NT	V 9	400	-111,0	111,0
30	61	83	3 NT	V 9	400	-111,0	111,0
11	81	43	3 NT	V 9	400	-111,0	111,0
18	25	17	3 NT	Ø 10	430	-145,0	145,0
5	37	46	3 NT	V 10	430	-145,0	145,0
24	65	39	3 NT	V 10	430	-145,0	145,0
29	42	86	3 NT	V 10	430	-145,0	145,0
17	18	27	3 NT	V 10	430	-145,0	145,0
15	22	49	3 NT	V 10	430	-145,0	145,0
7	60	66	3 NT	V 10	430	-145,0	145,0
31	59	34	3 NT	V 10	430	-145,0	145,0
33	89	45	3 NT	Ø 10	430	-145,0	145,0
40	67	14	3 NT	V 10	430	-145,0	145,0
39	92	55	3 NT	V 10	430	-145,0	145,0
25	68	29	3 NT	Ø 10	430	-145,0	145,0
23	75	11	3 NT	Ø 10	430	-145,0	145,0
26	70	64	3 NT	Ø 10	430	-145,0	145,0
1	88	78	3 NT	Ø 10	430	-145,0	145,0
3	9	90	3 NT	V 10	430	-145,0	145,0
16	87	93	3 NT	Ø 10	430	-145,0	145,0
47	48	15	3 NT	Ø 10	430	-145,0	145,0
2	13	53	3 NT	V 10	430	-145,0	145,0
8	76	28	3 NT	V 11	460	-188,0	188,0
28	62	1	3 NT	Ø 11	460	-188,0	188,0
36	52	77	3 NT	V 11	460	-188,0	188,0
44	63	57	3 NT	Ø 11	460	-188,0	188,0

# SPILLSTENSILER

Mappnr: **15(15)**  
 Rundenr: **5**  
 Syd / N/S

- ♠ AJT
- ♥ QJ64
- ♦ 52
- ♣ KJ32

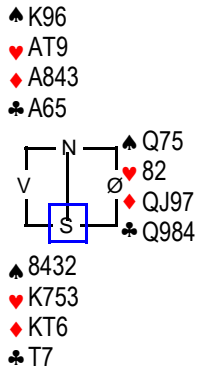

Bord	NS	ØV	NS	ØV	NS	ØV
13	16	23	1 NT D	N 8	380	
11	81	43	1 NT	N 9	150	159,0 -159,0
47	48	15	2 NT	N 9	150	159,0 -159,0
31	59	34	2 Hjerter	N 9	140	154,0 -154,0
4	6	31	1 NT	N 8	120	126,0 -126,0
46	94	54	1 NT	N 8	120	126,0 -126,0
7	60	66	1 NT	N 8	120	126,0 -126,0
37	51	58	2 Hjerter	S 8	110	108,0 -108,0
42	8	30	2 Hjerter	S 8	110	108,0 -108,0
3	9	90	2 Hjerter	S 8	110	108,0 -108,0
20	36	69	2 Hjerter	S 8	110	108,0 -108,0
21	74	20	2 Hjerter	S 8	110	108,0 -108,0
5	37	46	3 Kløver	V 7	100	96,0 -96,0
22	26	41	3 Kløver	V 7	100	96,0 -96,0
32	84	12	3 Kløver	V 7	100	96,0 -96,0
14	80	44	3 Kløver	V 7	100	96,0 -96,0
24	65	39	1 NT	N 7	90	83,0 -83,0
9	4	56	1 NT	N 7	90	83,0 -83,0
16	87	93	2 Ruter	N 8	90	83,0 -83,0
6	50	7	2 Ruter	N 8	90	83,0 -83,0
15	22	49	2 Ruter	N 8	90	83,0 -83,0
1	88	78	2 Ruter	N 8	90	83,0 -83,0
39	92	55	2 Ruter	N 8	90	83,0 -83,0
43	21	5	1 NT	V 6	50	33,0 -33,0
38	79	35	1 NT	Ø 6	50	33,0 -33,0
30	61	83	1 NT	Ø 6	50	33,0 -33,0
17	18	27	1 NT	Ø 6	50	33,0 -33,0
35	19	73	2 Kløver	V 7	50	33,0 -33,0
19	72	3	2 Ruter	Ø 7	50	33,0 -33,0
8	76	28	1 NT	Ø 7	90	-134,0 134,0
41	85	24	1 NT	Ø 7	90	-134,0 134,0
34	2	38	1 NT	Ø 7	90	-134,0 134,0
27	40	33	2 Kløver	V 8	90	-134,0 134,0
33	89	45	1 NT	N 6	100	-137,0 137,0
28	62	1	1 NT	N 6	100	-137,0 137,0
23	75	11	1 NT	N 6	100	-137,0 137,0
45	10	32	1 NT	N 6	100	-137,0 137,0
29	42	86	2 Hjerter	S 7	100	-137,0 137,0
2	13	53	2 Hjerter	S 7	100	-137,0 137,0
18	25	17	2 Hjerter	S 7	100	-137,0 137,0
40	67	14	2 Ruter	N 7	100	-137,0 137,0
36	52	77	2 Ruter	N 7	100	-137,0 137,0
26	70	64	1 NT	V 8	120	-173,0 173,0
44	63	57	1 NT D	N 6	200	-248,0 248,0
12	91	71	2 Hjerter	S 6	200	-248,0 248,0
25	68	29	2 Ruter	N 6	200	-248,0 248,0
10	82	47	4 Hjerter	S 8	200	-248,0 248,0

# IMP, 05. august 2010

Mappnr: **16(16)**  
 Rundenr: **6**  
 Vest / Ø/V

- ♠ AQ96
- ♥ QT3
- ♦ 852
- ♣ Q42

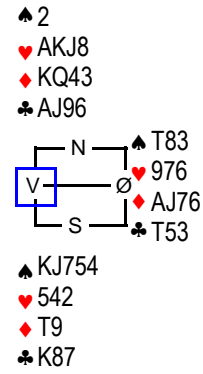

Bord	NS	ØV	NS	ØV	NS	ØV
4	78	81	4 Hjerter	N 11	450	238,0 -238,0
10	20	71	3 NT	N 10	430	195,0 -195,0
34	29	61	3 NT	N 10	430	195,0 -195,0
31	45	22	3 NT	N 10	430	195,0 -195,0
13	56	82	3 NT	N 10	430	195,0 -195,0
22	27	76	3 NT	S 10	430	195,0 -195,0
36	12	65	3 NT	N 10	430	195,0 -195,0
37	59	30	3 NT	N 10	430	195,0 -195,0
14	64	42	3 NT	N 10	430	195,0 -195,0
47	94	48	3 NT	S 10	430	195,0 -195,0
43	55	2	3 NT	N 10	430	195,0 -195,0
12	17	93	3 NT	N 10	430	195,0 -195,0
24	68	83	3 NT	N 10	430	195,0 -195,0
35	58	73	3 NT	N 10	430	195,0 -195,0
45	5	63	3 NT	N 10	430	195,0 -195,0
39	57	51	3 NT	N 10	430	195,0 -195,0
19	1	26	3 NT	N 10	430	195,0 -195,0
41	8	62	3 NT	N 10	430	195,0 -195,0
28	39	10	3 NT	N 10	430	195,0 -195,0
2	53	31	3 NT	N 10	430	195,0 -195,0
15	44	75	3 NT	N 10	430	195,0 -195,0
25	84	86	3 NT	N 9	400	166,0 -166,0
6	16	46	3 NT	N 9	400	166,0 -166,0
18	43	11	3 NT	N 9	400	166,0 -166,0
20	49	89	3 NT	N 9	400	166,0 -166,0
1	88	9	3 NT	N 9	400	166,0 -166,0
46	54	15	3 NT	N 9	400	166,0 -166,0
40	14	52	3 NT	N 9	400	166,0 -166,0
11	28	69	3 NT	N 9	400	166,0 -166,0
38	72	24	2 Spar	S 7	50	-271,0 271,0
44	35	32	3 NT	N 8	50	-271,0 271,0
21	79	7	3 NT	N 8	50	-271,0 271,0
3	90	13	3 NT	N 8	50	-271,0 271,0
32	36	19	3 NT	N 8	50	-271,0 271,0
9	23	87	3 NT	N 8	50	-271,0 271,0
26	34	25	3 NT	N 8	50	-271,0 271,0
33	33	67	3 NT	N 8	50	-271,0 271,0
30	77	38	3 NT	N 8	50	-271,0 271,0
29	40	70	3 NT	N 8	50	-271,0 271,0
5	6	50	3 NT	N 8	50	-271,0 271,0
7	66	37	3 NT	N 7	100	-332,0 332,0
27	41	74	3 NT	N 7	100	-332,0 332,0
23	80	18	3 NT	N 7	100	-332,0 332,0
16	4	91	3 NT	N 7	100	-332,0 332,0
8	47	60	3 NT	N 6	150	-357,0 357,0
17	92	3	6 Ruter	N 9	150	-357,0 357,0
42	21	85	3 NT D	N 7	300	-443,0 443,0



# SPILLSTENSILER

Mappnr: 17(17)  
Rundenr: 6

Nord / Ingen

♠ 75  
♥ K84  
♦ 52  
♣ QJT984

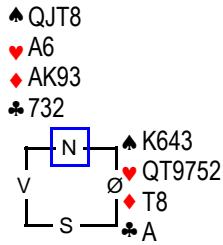

♠ A92  
♥ J3  
♦ QJ764  
♣ K65

Bord	NS	ØV		NS	ØV	NS	ØV
14	64	42	4 Hjerter D	Ø 7	500	274,0	-274,0
23	80	18	4 Hjerter D	Ø 7	500	274,0	-274,0
33	33	67	3 NT	N 11	460	232,0	-232,0
2	53	31	3 NT	S 10	430	196,0	-196,0
18	43	11	3 NT	S 10	430	196,0	-196,0
25	84	86	3 NT	N 10	430	196,0	-196,0
41	8	62	3 NT	N 10	430	196,0	-196,0
47	94	48	3 NT	N 10	430	196,0	-196,0
21	79	7	4 Spar	N 10	420	195,0	-195,0
29	40	70	3 NT	N 9	400	162,0	-162,0
26	34	25	3 NT	N 9	400	162,0	-162,0
17	92	3	3 NT	N 9	400	162,0	-162,0
13	56	82	3 NT	N 9	400	162,0	-162,0
12	17	93	3 NT	N 9	400	162,0	-162,0
27	41	74	3 NT	N 9	400	162,0	-162,0
35	58	73	3 NT	N 9	400	162,0	-162,0
39	57	51	3 NT	N 9	400	162,0	-162,0
42	21	85	3 NT	N 9	400	162,0	-162,0
1	88	9	3 NT	N 9	400	162,0	-162,0
22	27	76	3 NT	S 9	400	162,0	-162,0
34	29	61	5 Ruter	N 11	400	162,0	-162,0
32	36	19	5 Ruter	N 11	400	162,0	-162,0
5	6	50	5 Ruter	N 11	400	162,0	-162,0
38	72	24	4 Hjerter D	Ø 8	300	48,0	-48,0
24	68	83	3 Ruter	N 12	170	-92,0	92,0
45	5	63	3 Spar	N 10	170	-92,0	92,0
11	28	69	4 Ruter	N 12	170	-92,0	92,0
20	49	89	3 Ruter	N 11	150	-110,0	110,0
46	54	15	4 Ruter	S 11	150	-110,0	110,0
19	1	26	4 Ruter	N 11	150	-110,0	110,0
44	35	32	4 Ruter	N 11	150	-110,0	110,0
37	59	30	3 Ruter	S 10	130	-143,0	143,0
15	44	75	3 Ruter	N 10	130	-143,0	143,0
30	77	38	4 Ruter	N 10	130	-143,0	143,0
28	39	10	4 Ruter	N 10	130	-143,0	143,0
40	14	52	4 Ruter	N 10	130	-143,0	143,0
9	23	87	2 Hjerter D	Ø 7	100	-168,0	168,0
43	55	2	3 Hjerter	Ø 7	100	-168,0	168,0
31	45	22	3 Hjerter	Ø 8	50	-221,0	221,0
7	66	37	3 Hjerter	Ø 8	50	-221,0	221,0
6	16	46	3 Hjerter	Ø 8	50	-221,0	221,0
3	90	13	3 Hjerter	Ø 8	50	-221,0	221,0
10	20	71	3 Spar	N 8	50	-324,0	324,0
16	4	91	4 Spar	N 9	50	-324,0	324,0
8	47	60	5 Ruter	N 10	50	-324,0	324,0
36	12	65	5 Ruter	N 10	50	-324,0	324,0
4	78	81	5 Ruter	N 10	50	-324,0	324,0

# IMP, 05. august 2010

Mappnr: 18(18)  
Rundenr: 6

Øst / N/S

♠ A976  
♥ AT8  
♦ QJT95  
♣ A

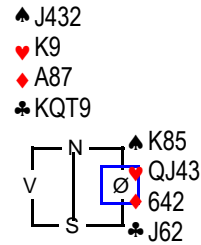

♠ QT  
♥ 7652  
♦ K3  
♣ 87543

Bord	NS	ØV		NS	ØV	NS	ØV
10	20	71	2 NT	Ø 5	150	253,0	-253,0
6	16	46	2 NT	Ø 5	150	253,0	-253,0
39	57	51	2 Kløver	S 9	110	211,0	-211,0
32	36	19	1 NT	Ø 5	100	201,0	-201,0
21	79	7	2 NT	Ø 6	100	201,0	-201,0
2	53	31	4 Hjerter	Ø 8	100	201,0	-201,0
26	34	25	1 NT	Ø 6	50	145,0	-145,0
14	64	42	1 NT	Ø 6	50	145,0	-145,0
29	40	70	1 Spar	V 6	50	145,0	-145,0
37	59	30	2 Hjerter	Ø 7	50	145,0	-145,0
44	35	32	3 Ruter	V 8	50	145,0	-145,0
15	44	75	1 Spar	V 7	80	-17,0	17,0
41	8	62	1 NT	Ø 7	90	-20,0	20,0
19	1	26	1 NT	V 7	90	-20,0	20,0
16	4	91	1 NT	V 7	90	-20,0	20,0
46	54	15	1 NT	Ø 7	90	-20,0	20,0
9	23	87	1 NT	V 7	90	-20,0	20,0
38	72	24	1 NT	Ø 7	90	-20,0	20,0
35	58	73	1 NT	V 7	90	-20,0	20,0
47	94	48	1 NT	Ø 7	90	-20,0	20,0
4	78	81	1 NT	V 7	90	-20,0	20,0
22	27	76	1 NT	V 7	90	-20,0	20,0
31	45	22	1 NT	V 7	90	-20,0	20,0
23	80	18	2 Ruter	V 8	90	-20,0	20,0
45	5	63	2 Ruter	V 8	90	-20,0	20,0
12	17	93	1 Spar	V 8	110	-54,0	54,0
24	68	83	1 Spar	V 8	110	-54,0	54,0
20	49	89	1 Spar	V 8	110	-54,0	54,0
13	56	82	2 Hjerter	Ø 8	110	-54,0	54,0
34	29	61	2 Hjerter	Ø 8	110	-54,0	54,0
36	12	65	2 Ruter	V 9	110	-54,0	54,0
27	41	74	2 Ruter	V 9	110	-54,0	54,0
33	33	67	3 Ruter	Ø 9	110	-54,0	54,0
11	28	69	1 NT	V 8	120	-66,0	66,0
43	55	2	1 NT	Ø 8	120	-66,0	66,0
30	77	38	2 Ruter	V 10	130	-77,0	77,0
7	66	37	2 Ruter	V 10	130	-77,0	77,0
1	88	9	3 Hjerter	V 9	140	-100,0	100,0
3	90	13	1 NT	V 9	150	-102,0	102,0
5	6	50	1 NT	V 9	150	-102,0	102,0
25	84	86	1 NT	V 9	150	-102,0	102,0
42	21	85	1 NT	V 9	150	-102,0	102,0
8	47	60	1 NT	V 9	150	-102,0	102,0
17	92	3	1 NT	V 9	150	-102,0	102,0
18	43	11	1 NT	V 9	150	-102,0	102,0
40	14	52	1 NT	V 9	150	-102,0	102,0
28	39	10	2 Hjerter	Ø 10	170	-134,0	134,0

# SPILLSTENSILER

Mappen: 19(19)  
Rundenr: 7

Syd / ØV

- ♠ T32
- ♥ Q
- ♦ KQT95
- ♣ AQ97

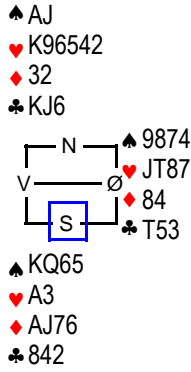

Bord	NS	ØV		NS	ØV	NS	ØV
43	32	62	4 Hjerter D	N 10	590	324,0	-324,0
42	73	52	1 Ruter R	S 8	430	139,0	-139,0
47	63	94	4 Hjerter	N 10	420	138,0	-138,0
31	25	72	4 Hjerter	N 10	420	138,0	-138,0
46	54	48	4 Hjerter	N 10	420	138,0	-138,0
7	60	28	4 Hjerter	N 10	420	138,0	-138,0
6	31	13	4 Hjerter	N 10	420	138,0	-138,0
35	61	41	4 Hjerter	N 10	420	138,0	-138,0
33	51	68	4 Hjerter	N 10	420	138,0	-138,0
19	92	77	4 Hjerter	N 10	420	138,0	-138,0
20	56	40	4 Hjerter	N 10	420	138,0	-138,0
39	24	58	4 Hjerter	N 10	420	138,0	-138,0
8	47	66	4 Hjerter	N 10	420	138,0	-138,0
4	46	78	4 Hjerter	N 10	420	138,0	-138,0
44	2	5	4 Hjerter	N 10	420	138,0	-138,0
18	86	43	4 Hjerter	N 10	420	138,0	-138,0
13	4	11	4 Hjerter	N 10	420	138,0	-138,0
24	42	29	4 Hjerter	N 10	420	138,0	-138,0
23	23	36	4 Hjerter	N 10	420	138,0	-138,0
32	22	57	4 Hjerter	N 10	420	138,0	-138,0
36	65	59	4 Hjerter	N 10	420	138,0	-138,0
28	10	3	4 Hjerter	N 10	420	138,0	-138,0
27	39	34	4 Hjerter	N 10	420	138,0	-138,0
38	30	67	4 Hjerter	N 10	420	138,0	-138,0
12	1	71	4 Hjerter	N 10	420	138,0	-138,0
26	84	89	4 Hjerter	N 10	420	138,0	-138,0
17	37	69	4 Hjerter	S 10	420	138,0	-138,0
34	70	14	4 Hjerter	N 10	420	138,0	-138,0
21	83	75	4 Hjerter	N 10	420	138,0	-138,0
11	20	80	4 Hjerter	N 10	420	138,0	-138,0
14	93	79	4 Hjerter	N 10	420	138,0	-138,0
22	38	19	3 NT	S 9	400	106,0	-106,0
16	27	49	3 NT	S 9	400	106,0	-106,0
1	53	88	2 Hjerter	N 10	170	-118,0	118,0
5	6	81	3 NT	S 8		50	-328,0 328,0
41	8	85	3 NT	S 8		50	-328,0 328,0
45	35	15	3 NT	N 8		50	-328,0 328,0
9	87	17	3 NT	S 8		50	-328,0 328,0
29	18	7	3 NT	N 8		50	-328,0 328,0
40	21	55	3 NT	N 8		50	-328,0 328,0
10	26	64	4 Hjerter	S 9		50	-328,0 328,0
37	12	33	4 Hjerter	N 9		50	-328,0 328,0
30	76	44	3 NT	S 7	100	-387,0 387,0	
2	9	16	3 NT	N 7	100	-387,0 387,0	
25	45	74	3 NT	S 7	100	-387,0 387,0	
3	50	90	3 NT D	N 8	100	-387,0 387,0	
15	82	91	3 NT	S 7	100	-387,0 387,0	

# IMP, 05. august 2010

Mappen: 20(20)  
Rundenr: 7

Vest / Alle

- ♠ 9532
- ♥ 5
- ♦ KT42
- ♣ AKT5

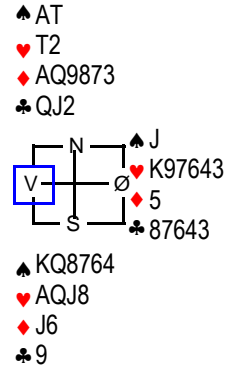

Bord	NS	ØV		NS	ØV	NS	ØV
33	51	68	2 Hjerter D	Ø 2	1700	642,0	-642,0
38	30	67	3 Hjerter D	Ø 3	1700	642,0	-642,0
17	37	69	6 Spar	S 12	1430	555,0	-555,0
25	45	74	2 Hjerter D	Ø 4	1100	389,0	-389,0
12	1	71	4 Hjerter D	Ø 6	1100	389,0	-389,0
4	46	78	5 Ruter D	N 12	950	282,0	-282,0
26	84	89	5 Spar D	S 11	850	199,0	-199,0
41	8	85	2 Hjerter D	Ø 5	800	146,0	-146,0
19	92	77	3 Hjerter D	Ø 6	800	146,0	-146,0
32	22	57	4 Kløver D	Ø 7	800	146,0	-146,0
31	25	72	5 Kløver D	Ø 8	800	146,0	-146,0
37	12	33	4 Spar D	S 10	790	138,0	-138,0
9	87	17	3 NT	N 13	720	66,0	-66,0
39	24	58	3 NT	S 12	690	29,0	-29,0
3	50	90	3 NT	N 12	690	29,0	-29,0
28	10	3	4 Spar	S 12	680	25,0	-25,0
15	82	91	4 Spar	S 12	680	25,0	-25,0
45	35	15	4 Spar	S 12	680	25,0	-25,0
46	54	48	4 Spar	S 12	680	25,0	-25,0
21	83	75	4 Spar	S 12	680	25,0	-25,0
29	18	7	4 Spar	S 12	680	25,0	-25,0
10	26	64	4 Spar	S 11	650	-10,0	10,0
27	39	34	4 Spar	S 11	650	-10,0	10,0
22	38	19	4 Spar	S 11	650	-10,0	10,0
8	47	66	4 Spar	S 11	650	-10,0	10,0
36	65	59	4 Spar	S 11	650	-10,0	10,0
14	93	79	4 Spar	S 11	650	-10,0	10,0
24	42	29	3 NT	N 10	630	-43,0	43,0
40	21	55	3 NT	S 10	630	-43,0	43,0
18	86	43	4 Spar	S 10	620	-49,0	49,0
44	2	5	4 Spar	S 10	620	-49,0	49,0
20	56	40	4 Spar	S 10	620	-49,0	49,0
34	70	14	4 Spar	S 10	620	-49,0	49,0
11	20	80	4 Spar	S 10	620	-49,0	49,0
16	27	49	4 Spar	S 10	620	-49,0	49,0
42	73	52	4 Spar	S 10	620	-49,0	49,0
7	60	28	4 Spar	S 10	620	-49,0	49,0
43	32	62	4 Spar	S 10	620	-49,0	49,0
13	4	11	3 NT	N 9	600	-74,0	74,0
35	61	41	4 Kløver D	V 8	500	-170,0	170,0
30	76	44	3 Hjerter	Ø 6	300	-343,0	343,0
23	23	36	1 Spar	S 11	200	-411,0	411,0
47	63	94	2 Hjerter D	Ø 7	200	-411,0	411,0
1	53	88	2 Spar	S 11	200	-411,0	411,0
6	31	13	3 Spar	S 11	200	-411,0	411,0
5	6	81	6 Spar	S 10		200	-588,0 588,0
2	9	16	6 Spar D	S 10		500	-688,0 688,0

# SPILLSTENSILER

Mappenr: 21(21)  
Rundenr: 7

Nord / N/S

- ♠ AQ8
- ♥ AJ3
- ♦ 9652
- ♣ QT8

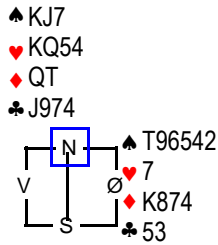

- ♠ 3
- ♥ T9862
- ♦ AJ3
- ♣ AK62

Bord	NS	ØV	NS	ØV	NS	ØV
45	35	15	4 Spar D	Ø 6	800	296,0 -296,0
23	23	36	4 Spar D	Ø 6	800	296,0 -296,0
46	54	48	4 Hjerter	S 11	650	134,0 -134,0
4	46	78	4 Hjerter	S 11	650	134,0 -134,0
17	37	69	4 Hjerter	S 11	650	134,0 -134,0
6	31	13	4 Hjerter	S 11	650	134,0 -134,0
41	8	85	4 Hjerter	S 11	650	134,0 -134,0
11	20	80	4 Hjerter	N 11	650	134,0 -134,0
19	92	77	4 Hjerter	S 11	650	134,0 -134,0
18	86	43	4 Hjerter	S 11	650	134,0 -134,0
22	38	19	5 Hjerter	S 11	650	134,0 -134,0
15	82	91	5 Hjerter	S 11	650	134,0 -134,0
40	21	55	3 NT	N 10	630	97,0 -97,0
44	2	5	4 Hjerter	S 10	620	92,0 -92,0
42	73	52	4 Hjerter	S 10	620	92,0 -92,0
31	25	72	4 Hjerter	S 10	620	92,0 -92,0
28	10	3	4 Hjerter	S 10	620	92,0 -92,0
39	24	58	4 Hjerter	S 10	620	92,0 -92,0
30	76	44	4 Hjerter	N 10	620	92,0 -92,0
25	45	74	4 Hjerter	S 10	620	92,0 -92,0
33	51	68	4 Hjerter	N 10	620	92,0 -92,0
1	53	88	4 Hjerter	S 10	620	92,0 -92,0
10	26	64	4 Hjerter	S 10	620	92,0 -92,0
16	27	49	4 Hjerter	S 10	620	92,0 -92,0
7	60	28	4 Hjerter	N 10	620	92,0 -92,0
43	32	62	4 Hjerter	N 10	620	92,0 -92,0
35	61	41	4 Hjerter	N 10	620	92,0 -92,0
5	6	81	4 Hjerter	S 10	620	92,0 -92,0
9	87	17	4 Hjerter	S 10	620	92,0 -92,0
3	50	90	4 Hjerter	S 10	620	92,0 -92,0
21	83	75	4 Hjerter	S 10	620	92,0 -92,0
14	93	79	4 Hjerter	S 10	620	92,0 -92,0
27	39	34	4 Hjerter	S 10	620	92,0 -92,0
38	30	67	4 Spar	S 10	620	92,0 -92,0
32	22	57	3 NT	N 9	600	58,0 -58,0
26	84	89	4 Spar D	Ø 7	500	-34,0 34,0
12	1	71	4 Spar D	Ø 7	500	-34,0 34,0
8	47	66	4 Spar D	Ø 8	300	-238,0 238,0
29	18	7	3 Hjerter	S 11	200	-315,0 315,0
13	4	11	3 Hjerter	S 11	200	-315,0 315,0
36	65	59	4 Spar	Ø 6	200	-315,0 315,0
37	12	33	3 Hjerter	S 10	170	-345,0 345,0
34	70	14	3 Hjerter	S 10	170	-345,0 345,0
2	9	16	5 Hjerter	N 10	100	-496,0 496,0
47	63	94	5 Hjerter	S 10	100	-496,0 496,0
24	42	29	5 Hjerter D	S 10	200	-543,0 543,0
20	56	40	5 Hjerter D	S 10	200	-543,0 543,0

# IMP, 05. august 2010

Mappenr: 22(22)  
Rundenr: 8

Øst / Ø/V

- ♠ 76
- ♥ JT853
- ♦ KT43
- ♣ Q4

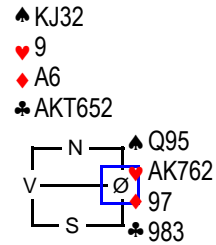

- ♠ AT84
- ♥ Q4
- ♦ QJ852
- ♣ J7

Bord	NS	ØV	NS	ØV	NS	ØV
40	32	61	3 Spar D	Ø 4	1400	642,0 -642,0
16	57	29	6 Spar	N 12	980	491,0 -491,0
9	28	31	4 Spar	S 12	480	28,0 -28,0
30	22	59	4 Spar	N 12	480	28,0 -28,0
19	11	90	4 Spar	N 12	480	28,0 -28,0
17	74	69	4 Spar	S 12	480	28,0 -28,0
38	15	33	4 Spar	N 12	480	28,0 -28,0
23	10	83	4 Spar	N 12	480	28,0 -28,0
5	78	6	4 Spar	N 12	480	28,0 -28,0
47	48	63	4 Spar	S 12	480	28,0 -28,0
3	13	60	4 Spar	N 12	480	28,0 -28,0
10	20	27	4 Spar	N 12	480	28,0 -28,0
29	7	68	4 Spar	N 12	480	28,0 -28,0
6	46	64	4 Spar	N 12	480	28,0 -28,0
28	4	39	4 Spar	N 12	480	28,0 -28,0
34	24	8	4 Spar	N 12	480	28,0 -28,0
39	41	12	4 Spar	N 12	480	28,0 -28,0
45	94	62	4 Spar	S 12	480	28,0 -28,0
11	26	79	4 Spar	N 12	480	28,0 -28,0
32	58	65	4 Spar	N 12	480	28,0 -28,0
33	85	70	4 Spar	N 11	450	-16,0 16,0
13	38	43	4 Spar	N 11	450	-16,0 16,0
25	89	18	4 Spar	N 11	450	-16,0 16,0
31	77	25	4 Spar	N 11	450	-16,0 16,0
42	52	30	4 Spar	N 11	450	-16,0 16,0
43	51	2	4 Spar	N 11	450	-16,0 16,0
26	34	45	4 Spar	N 11	450	-16,0 16,0
35	72	23	4 Spar	S 11	450	-16,0 16,0
4	81	9	4 Spar	N 11	450	-16,0 16,0
2	88	50	4 Spar	S 11	450	-16,0 16,0
20	3	36	4 Spar	N 11	450	-16,0 16,0
1	53	16	4 Spar	N 11	450	-16,0 16,0
24	75	19	4 Spar	N 11	450	-16,0 16,0
7	91	87	4 Spar	S 11	450	-16,0 16,0
36	76	14	5 Spar	S 11	450	-16,0 16,0
22	86	47	4 Spar	N 10	420	-60,0 60,0
41	5	55	4 Spar	N 10	420	-60,0 60,0
44	73	21	4 Spar	N 10	420	-60,0 60,0
27	44	92	4 Spar	N 10	420	-60,0 60,0
12	1	80	4 Spar	N 10	420	-60,0 60,0
15	66	49	4 Spar	N 10	420	-60,0 60,0
18	84	40	4 Spar	N 10	420	-60,0 60,0
14	71	56	4 Spar	N 10	420	-60,0 60,0
21	93	82	4 Spar	N 10	420	-60,0 60,0
46	35	54	4 Spar	N 10	420	-60,0 60,0
37	67	42	3 Spar	N 11	200	-298,0 298,0
8	17	37	3 NT	S 8	50	-499,0 499,0

# SPILLSTENSILER

Mappenr: **23(23)**  
Rundenr: **8**

Syd / Alle

♠ KT754  
♥ 75  
♦ AJT  
♣ QT7

♠ 92  
♥ K9642  
♦ 65  
♣ K986

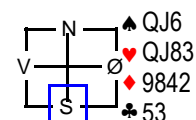

♠ A83  
♥ AT  
♦ KQ73  
♣ AJ42

Bord	NS	ØV		NS	ØV	NS	ØV
2	88	50	2 Hjerter	S 9	140	315,0	-315,0
9	28	31	2 Hjerter	S 9	140	315,0	-315,0
19	11	90	2 Hjerter	S 9	140	315,0	-315,0
15	66	49	2 Hjerter	S 9	140	315,0	-315,0
5	78	6	4 Kløver	S 10	130	315,0	-315,0
13	38	43	4 Kløver	S 10	130	315,0	-315,0
37	67	42	2 Hjerter	S 8	110	270,0	-270,0
33	85	70	2 Hjerter	S 8	110	270,0	-270,0
18	84	40	2 Hjerter	S 8	110	270,0	-270,0
44	73	21	3 Kløver	S 9	110	270,0	-270,0
30	22	59	2 Hjerter	S 7	100	68,0	-68,0
22	86	47	2 NT	S 7	100	68,0	-68,0
11	26	79	2 NT	S 7	100	68,0	-68,0
1	53	16	3 Hjerter	N 8	100	68,0	-68,0
7	91	87	3 NT	S 8	100	68,0	-68,0
20	3	36	3 NT	S 8	100	68,0	-68,0
3	13	60	5 Kløver	S 10	100	68,0	-68,0
40	32	61	2 NT	S 6	200	-50,0	50,0
14	71	56	3 NT	S 7	200	-50,0	50,0
10	20	27	3 NT	S 7	200	-50,0	50,0
45	94	62	3 NT	S 7	200	-50,0	50,0
17	74	69	3 NT	S 7	200	-50,0	50,0
23	10	83	3 NT	S 7	200	-50,0	50,0
28	4	39	3 NT	S 7	200	-50,0	50,0
35	72	23	3 NT	S 7	200	-50,0	50,0
16	57	29	3 NT	S 7	200	-50,0	50,0
36	76	14	3 NT	S 7	200	-50,0	50,0
34	24	8	3 NT	S 7	200	-50,0	50,0
32	58	65	3 NT	S 7	200	-50,0	50,0
21	93	82	4 Hjerter	N 8	200	-50,0	50,0
24	75	19	4 Hjerter	N 8	200	-50,0	50,0
12	1	80	4 Hjerter	N 8	200	-50,0	50,0
6	46	64	4 Kløver	S 8	200	-50,0	50,0
42	52	30	5 Kløver	S 9	200	-50,0	50,0
25	89	18	3 NT	S 6	300	-172,0	172,0
31	77	25	3 NT	S 6	300	-172,0	172,0
39	41	12	3 NT	S 6	300	-172,0	172,0
43	51	2	3 NT	S 6	300	-172,0	172,0
46	35	54	3 NT	S 6	300	-172,0	172,0
38	15	33	3 NT	S 6	300	-172,0	172,0
8	17	37	3 NT	S 6	300	-172,0	172,0
26	34	45	3 NT	S 6	300	-172,0	172,0
4	81	9	3 NT	S 6	300	-172,0	172,0
41	5	55	4 Hjerter	N 7	300	-172,0	172,0
27	44	92	4 Hjerter	N 7	300	-172,0	172,0
47	48	63	3 NT	S 5	400	-272,0	272,0
29	7	68	6 NT	S 6	600	-432,0	432,0

# IMP, 05. august 2010

Mappenr: **24(24)**  
Rundenr: **8**

Vest / Ingen

♠ T64  
♥ 7  
♦ AJT9  
♣ JT853

♠ QJ92  
♥ 4  
♦ Q842  
♣ AQ72

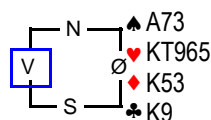

♠ K85  
♥ AQJ832  
♦ 76  
♣ 64

Bord	NS	ØV		NS	ØV	NS	ØV
22	86	47	2 NT D	V 3	1100	658,0	-658,0
32	58	65	2 Kløver D	V 5	500	428,0	-428,0
27	44	92	1 Hjerter D	Ø 5	300	264,0	-264,0
41	5	55	1 Hjerter D	Ø 5	300	264,0	-264,0
33	85	70	1 Hjerter D	Ø 5	300	264,0	-264,0
9	28	31	1 Hjerter D	Ø 5	300	264,0	-264,0
16	57	29	1 Hjerter D	Ø 5	300	264,0	-264,0
28	4	39	2 Hjerter	S 8	110	66,0	-66,0
24	75	19	1 Hjerter	Ø 5	100	63,0	-63,0
14	71	56	1 Hjerter D	Ø 6	100	63,0	-63,0
15	66	49	1 Hjerter D	Ø 6	100	63,0	-63,0
21	93	82	1 Hjerter	Ø 5	100	63,0	-63,0
8	17	37	1 NT	V 5	100	63,0	-63,0
25	89	18	1 NT D	V 6	100	63,0	-63,0
13	38	43	1 NT D	V 6	100	63,0	-63,0
31	77	25	1 NT D	Ø 6	100	63,0	-63,0
5	78	6	1 NT D	V 6	100	63,0	-63,0
45	94	62	1 NT D	V 6	100	63,0	-63,0
10	20	27	1 Spar D	Ø 6	100	63,0	-63,0
39	41	12	2 Kløver D	Ø 7	100	63,0	-63,0
3	13	60	2 Ruter D	V 7	100	63,0	-63,0
23	10	83	1 NT	S 7	90	57,0	-57,0
2	88	50	1 NT	S 7	90	57,0	-57,0
12	1	80	1 NT	S 7	90	57,0	-57,0
1	53	16	1 Hjerter	Ø 6	50	-2,0	2,0
17	74	69	1 NT	V 6	50	-2,0	2,0
38	15	33	1 NT	V 6	50	-2,0	2,0
34	24	8	1 NT	V 6	50	-2,0	2,0
40	32	61	1 NT	Ø 6	50	-2,0	2,0
6	46	64	1 NT	S 6	50	-108,0	108,0
19	11	90	2 Spar	N 7	50	-108,0	108,0
42	52	30	2 Spar	N 7	50	-108,0	108,0
11	26	79	2 Spar	S 7	50	-108,0	108,0
36	76	14	2 Spar	N 7	50	-108,0	108,0
37	67	42	2 Spar	N 7	50	-108,0	108,0
47	48	63	2 NT	S 6	100	-168,0	168,0
26	34	45	2 NT	S 6	100	-168,0	168,0
7	91	87	2 Spar	S 6	100	-168,0	168,0
44	73	21	2 Spar	S 6	100	-168,0	168,0
46	35	54	3 NT	S 7	100	-168,0	168,0
30	22	59	1 NT	S 4	150	-219,0	219,0
43	51	2	2 Kløver D	V 8	180	-254,0	254,0
4	81	9	2 Kløver D	V 8	180	-254,0	254,0
20	3	36	2 Ruter D	V 8	180	-254,0	254,0
18	84	40	3 Spar	N 5	200	-271,0	271,0
35	72	23	2 Kløver D	V 9	280	-352,0	352,0
29	7	68	3 NT D	N 7	300	-360,0	360,0

# SPILLSTENSILER

Mappnr: 25(25)  
Rundenr: 9

Nord / ØV

- ♠ A4
- ♥ QT854
- ♦ T953
- ♣ 84

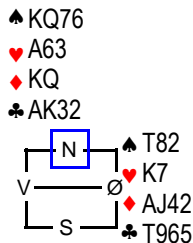

- ♠ J953
- ♥ J92
- ♦ 876
- ♣ QJ7

Bord	NS	ØV	NS	ØV	NS	ØV
26	82	57	3 NT	N 11	460	122,0 -122,0
16	83	7	3 NT	N 10	430	80,0 -80,0
5	46	50	4 Spar	N 10	420	80,0 -80,0
42	76	5	4 Spar	N 10	420	80,0 -80,0
7	87	1	4 Spar	N 10	420	80,0 -80,0
45	54	67	4 Spar	N 10	420	80,0 -80,0
30	19	26	4 Spar	N 10	420	80,0 -80,0
4	13	37	4 Spar	N 10	420	80,0 -80,0
34	32	65	4 Spar	N 10	420	80,0 -80,0
19	49	9	4 Spar	N 10	420	80,0 -80,0
25	71	3	4 Spar	N 10	420	80,0 -80,0
20	74	77	4 Spar	N 10	420	80,0 -80,0
36	18	61	4 Spar	N 10	420	80,0 -80,0
12	6	84	4 Spar	N 10	420	80,0 -80,0
11	31	40	4 Spar	N 10	420	80,0 -80,0
44	12	21	4 Spar	N 10	420	80,0 -80,0
31	34	4	4 Spar	N 10	420	80,0 -80,0
29	14	75	4 Spar	N 10	420	80,0 -80,0
14	90	93	4 Spar	N 10	420	80,0 -80,0
28	33	59	4 Spar	N 10	420	80,0 -80,0
40	72	2	4 Spar	N 10	420	80,0 -80,0
13	44	66	4 Spar	S 10	420	80,0 -80,0
23	25	56	4 Spar	N 10	420	80,0 -80,0
9	27	38	3 NT	N 9	400	36,0 -36,0
10	29	28	3 NT	N 9	400	36,0 -36,0
41	73	42	3 NT	N 9	400	36,0 -36,0
8	20	78	3 NT	N 9	400	36,0 -36,0
32	89	85	3 NT	N 9	400	36,0 -36,0
39	41	94	3 NT	N 9	400	36,0 -36,0
43	68	52	3 NT	N 9	400	36,0 -36,0
1	16	88	3 NT	N 9	400	36,0 -36,0
38	58	15	3 NT	N 9	400	36,0 -36,0
27	24	30	3 NT	N 9	400	36,0 -36,0
47	62	48	3 NT	N 9	400	36,0 -36,0
17	79	10	3 NT	N 9	400	36,0 -36,0
6	91	17	3 NT	N 9	400	36,0 -36,0
18	80	43	3 NT	N 9	400	36,0 -36,0
33	23	8	3 NT	N 9	400	36,0 -36,0
37	55	70	3 NT	N 9	400	36,0 -36,0
15	11	86	2 NT	N 9	150	-242,0 242,0
22	36	45	2 NT	S 9	150	-242,0 242,0
35	69	92	2 NT	N 9	150	-242,0 242,0
3	53	60	2 NT	N 9	150	-242,0 242,0
2	64	81	2 NT	N 9	150	-242,0 242,0
21	39	22	4 Spar	N 9	50	-416,0 416,0
24	47	51	4 Spar	N 9	50	-416,0 416,0
46	63	35	4 Spar	N 9	50	-416,0 416,0

# IMP, 05. august 2010

Mappnr: 26(26)  
Rundenr: 9

Øst / Alle

- ♠ AT432
- ♥ 7
- ♦ AT95
- ♣ 854

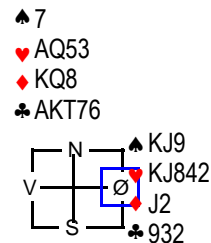

- ♠ Q865
- ♥ T96
- ♦ 7643
- ♣ QJ

Bord	NS	ØV	NS	ØV	NS	ØV
7	87	1	3 NT	N 9	600	518,0 -518,0
9	27	38	3 Spar D	Ø 7	500	467,0 -467,0
18	80	43	3 Spar D	V 7	500	467,0 -467,0
5	46	50	2 Spar	V 6	200	238,0 -238,0
21	39	22	3 Spar	V 7	200	238,0 -238,0
31	34	4	3 Spar	V 7	200	238,0 -238,0
22	36	45	1 NT	N 9	150	181,0 -181,0
33	23	8	2 NT	N 9	150	181,0 -181,0
30	19	26	2 Kløver	N 10	130	167,0 -167,0
1	16	88	2 NT	N 8	120	157,0 -157,0
46	63	35	2 NT	N 8	120	157,0 -157,0
23	25	56	2 NT	N 8	120	157,0 -157,0
35	69	92	2 NT	N 8	120	157,0 -157,0
37	55	70	1 Kløver	N 9	110	138,0 -138,0
19	49	9	2 Kløver	N 9	110	138,0 -138,0
3	53	60	2 Kløver	N 9	110	138,0 -138,0
34	32	65	2 Kløver	N 9	110	138,0 -138,0
13	44	66	2 Kløver	N 9	110	138,0 -138,0
14	90	93	2 Kløver	N 9	110	138,0 -138,0
43	68	52	2 Kløver	N 9	110	138,0 -138,0
25	71	3	3 Kløver	N 9	110	138,0 -138,0
28	33	59	3 Spar	Ø 8	100	129,0 -129,0
27	24	30	3 Spar	V 8	100	129,0 -129,0
40	72	2	1 Ruter	N 8	90	117,0 -117,0
44	12	21	1 Hjerter	Ø 7	80	-55,0 55,0
32	89	85	2 NT	S 7	100	-74,0 74,0
38	58	15	3 Kløver	N 8	100	-74,0 74,0
47	62	48	3 NT	N 8	100	-74,0 74,0
2	64	81	3 NT	N 8	100	-74,0 74,0
6	91	17	3 NT	S 8	100	-74,0 74,0
36	18	61	2 Spar	V 8	110	-82,0 82,0
29	14	75	2 Spar	V 10	170	-148,0 148,0
45	54	67	2 NT	N 6	200	-176,0 176,0
4	13	37	2 Ruter	S 6	200	-176,0 176,0
42	76	5	3 Hjerter	N 7	200	-176,0 176,0
26	82	57	3 Kløver	N 7	200	-176,0 176,0
15	11	86	3 NT	S 7	200	-176,0 176,0
20	74	77	3 Ruter	S 7	200	-176,0 176,0
12	6	84	4 Kløver	N 8	200	-176,0 176,0
16	83	7	4 Ruter	S 8	200	-176,0 176,0
10	29	28	4 Hjerter	S 7	300	-273,0 273,0
8	20	78	4 Ruter	S 7	300	-273,0 273,0
11	31	40	3 Kløver	N 5	400	-360,0 360,0
39	41	94	5 Kløver	N 7	400	-360,0 360,0
17	79	10	3 NT D	S 7	500	-427,0 427,0
41	73	42	2 Spar D	Ø 8	670	-523,0 523,0
24	47	51	2 Spar D	Ø 8	670	-523,0 523,0

# SPILLSTENSILER

Mappnr: 27(27)  
Rundenr: 9

Syd / Ingen

- ♠ T32
- ♥ AT
- ♦ AQJT9
- ♣ T75

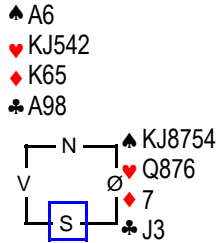

- ♠ Q9
- ♥ 93
- ♦ 8432
- ♣ KQ642

Bord	NS	ØV		NS	ØV	NS	ØV
24	47	51	3 NT	N 9	400	472,0	-472,0
34	32	65	4 Spar D	Ø 8	300	397,0	-397,0
28	33	59	4 Spar	Ø 8	100	213,0	-213,0
14	90	93	4 Spar	Ø 8	100	213,0	-213,0
16	83	7	4 Spar	Ø 8	100	213,0	-213,0
9	27	38	3 Spar	V 8	50	155,0	-155,0
2	64	81	3 Spar	Ø 8	50	155,0	-155,0
43	68	52	3 Spar	Ø 8	50	155,0	-155,0
18	80	43	3 Spar	Ø 8	50	155,0	-155,0
7	87	1	3 Spar	Ø 8	50	155,0	-155,0
30	19	26	3 Spar	Ø 8	50	155,0	-155,0
29	14	75	4 Spar	Ø 9	50	155,0	-155,0
3	53	60	4 Spar	Ø 9	50	155,0	-155,0
36	18	61	2 NT	S 7	50	50,0	-50,0
1	16	88	3 Kløver	N 8	50	50,0	-50,0
23	25	56	3 Hjerter D	N 8	100	-16,0	16,0
12	6	84	3 Kløver	S 7	100	-16,0	16,0
5	46	50	3 Kløver	S 7	100	-16,0	16,0
6	91	17	3 NT	N 7	100	-16,0	16,0
38	58	15	2 Hjerter	Ø 8	110	-19,0	19,0
17	79	10	2 Spar	Ø 8	110	-19,0	19,0
27	24	30	2 Spar	Ø 8	110	-19,0	19,0
8	20	78	2 Spar	Ø 8	110	-19,0	19,0
42	76	5	2 Spar	Ø 8	110	-19,0	19,0
46	63	35	2 Spar	Ø 8	110	-19,0	19,0
21	39	22	2 Spar	Ø 8	110	-19,0	19,0
13	44	66	2 Spar	Ø 8	110	-19,0	19,0
40	72	2	2 Spar	Ø 8	110	-19,0	19,0
31	34	4	2 Spar	Ø 8	110	-19,0	19,0
15	11	86	2 Spar	Ø 9	140	-64,0	64,0
11	31	40	2 Spar	Ø 9	140	-64,0	64,0
22	36	45	3 Spar	Ø 9	140	-64,0	64,0
26	82	57	4 Kløver	S 7	150	-68,0	68,0
45	54	67	4 Kløver	S 7	150	-68,0	68,0
47	62	48	3 Spar	Ø 10	170	-104,0	104,0
4	13	37	3 Spar	Ø 10	170	-104,0	104,0
41	73	42	2 Spar	Ø 11	200	-139,0	139,0
10	29	28	2 Spar	Ø 11	200	-139,0	139,0
20	74	77	2 Spar	V 11	200	-139,0	139,0
32	89	85	3 Spar	V 11	200	-139,0	139,0
44	12	21	3 Spar	Ø 11	200	-139,0	139,0
35	69	92	3 Spar	Ø 11	200	-139,0	139,0
37	55	70	3 Spar	Ø 11	200	-139,0	139,0
33	23	8	3 Hjerter D	N 7	300	-243,0	243,0
39	41	94	3 Kløver D	S 7	300	-243,0	243,0
19	49	9	3 Kløver D	S 7	300	-243,0	243,0
25	71	3	4 Spar	Ø 10	420	-356,0	356,0

# IMP, 05. august 2010

Mappnr: 28(28)  
Rundenr: 10

Vest / N/S

- ♠ QT62
- ♥ AK
- ♦ T96
- ♣ AQ84

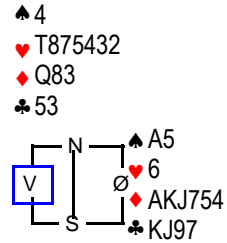

- ♠ KJ9873
- ♥ QJ9
- ♦ 2
- ♣ T62

Bord	NS	ØV		NS	ØV	NS	ØV
25	59	23	6 NT	V 11	50	493,0	-493,0
19	92	90	6 NT	V 11	50	493,0	-493,0
45	21	67	6 NT	V 11	50	493,0	-493,0
9	86	20	7 Kløver	V 12	50	493,0	-493,0
31	68	4	7 Kløver	V 12	50	493,0	-493,0
18	10	93	7 NT	V 12	50	493,0	-493,0
13	9	44	7 Ruter	Ø 12	50	493,0	-493,0
34	2	69	7 Ruter	V 12	50	493,0	-493,0
15	80	26	7 Ruter	Ø 12	50	493,0	-493,0
37	94	47	7 Kløver	S 12	100	413,0	-413,0
42	52	12	3 Ruter	Ø 13	190	358,0	-358,0
16	79	71	2 NT	V 11	210	344,0	-344,0
40	65	73	2 NT	V 12	240	329,0	-329,0
29	19	24	2 NT	V 13	270	313,0	-313,0
3	81	53	4 NT	V 13	520	164,0	-164,0
32	56	7	4 NT	V 13	520	164,0	-164,0
24	33	14	5 NT	Ø 13	520	164,0	-164,0
6	50	28	6 Ruter	Ø 12	920	-146,0	146,0
33	8	89	6 Ruter	Ø 12	920	-146,0	146,0
2	88	13	6 Ruter	Ø 12	920	-146,0	146,0
11	40	11	6 Ruter	Ø 12	920	-146,0	146,0
4	60	46	6 Ruter	V 12	920	-146,0	146,0
39	77	42	6 Ruter	Ø 12	920	-146,0	146,0
41	5	54	6 Ruter	Ø 12	920	-146,0	146,0
36	55	34	6 Ruter	Ø 12	920	-146,0	146,0
30	3	58	6 Ruter	Ø 12	920	-146,0	146,0
26	22	82	6 Ruter	V 12	920	-146,0	146,0
8	91	1	6 Ruter	Ø 12	920	-146,0	146,0
10	27	66	6 Ruter	Ø 12	920	-146,0	146,0
23	31	39	6 Ruter	Ø 12	920	-146,0	146,0
28	30	75	6 Kløver	V 13	940	-174,0	174,0
35	51	18	6 Kløver	V 13	940	-174,0	174,0
7	38	87	6 Ruter	Ø 13	940	-174,0	174,0
14	45	84	6 Ruter	Ø 13	940	-174,0	174,0
1	16	37	6 Ruter	Ø 13	940	-174,0	174,0
43	70	61	6 Ruter	Ø 13	940	-174,0	174,0
47	48	35	6 Ruter	Ø 13	940	-174,0	174,0
27	43	49	6 Ruter	Ø 13	940	-174,0	174,0
38	15	41	6 NT	V 13	1020	-242,0	242,0
20	25	85	6 NT	V 13	1020	-242,0	242,0
46	62	63	6 NT	V 13	1020	-242,0	242,0
44	72	76	6 NT	V 13	1020	-242,0	242,0
22	29	32	6 NT	V 13	1020	-242,0	242,0
17	36	83	7 Kløver	V 13	1440	-536,0	536,0
21	6	74	7 Kløver	V 13	1440	-536,0	536,0
5	64	78	7 Ruter	Ø 13	1440	-536,0	536,0
12	17	57	7 NT	V 13	1520	-578,0	578,0

# SPILLSTENSILER

Mappern: **29(29)**  
Rundenr: **10**

Nord / Alle

♠ AQ64  
♥ 852  
♦ A742  
♣ 82

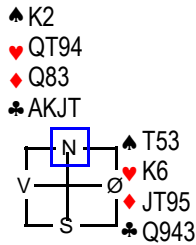

♠ J987  
♥ AJ73  
♦ K6  
♣ 765

Bord	NS	ØV	NS	ØV	NS	ØV
25	59	23	4 Hjerter	N 12	680	195,0 -195,0
35	51	18	4 Hjerter	N 12	680	195,0 -195,0
42	52	12	4 Hjerter	N 11	650	157,0 -157,0
10	27	66	4 Hjerter	N 11	650	157,0 -157,0
7	38	87	4 Hjerter	N 11	650	157,0 -157,0
17	36	83	4 Hjerter	N 11	650	157,0 -157,0
22	29	32	4 Hjerter	N 11	650	157,0 -157,0
40	65	73	4 Hjerter	N 11	650	157,0 -157,0
38	15	41	4 Hjerter	N 11	650	157,0 -157,0
21	6	74	4 Hjerter	N 10	620	113,0 -113,0
14	45	84	4 Hjerter	N 10	620	113,0 -113,0
47	48	35	4 Hjerter	N 10	620	113,0 -113,0
23	31	39	4 Hjerter	N 10	620	113,0 -113,0
19	92	90	4 Hjerter	N 10	620	113,0 -113,0
45	21	67	4 Hjerter	N 10	620	113,0 -113,0
20	25	85	4 Hjerter	N 10	620	113,0 -113,0
9	86	20	4 Hjerter	N 10	620	113,0 -113,0
1	16	37	4 Hjerter	N 10	620	113,0 -113,0
32	56	7	4 Hjerter	N 10	620	113,0 -113,0
33	8	89	4 Hjerter	N 10	620	113,0 -113,0
31	68	4	4 Hjerter	N 10	620	113,0 -113,0
11	40	11	4 Hjerter	N 10	620	113,0 -113,0
16	79	71	4 Hjerter	N 10	620	113,0 -113,0
13	9	44	4 Hjerter	N 10	620	113,0 -113,0
41	5	54	4 Hjerter	N 10	620	113,0 -113,0
26	22	82	4 Hjerter	N 10	620	113,0 -113,0
30	3	58	4 Hjerter	N 10	620	113,0 -113,0
15	80	26	4 Hjerter	N 10	620	113,0 -113,0
37	94	47	4 Hjerter	N 10	620	113,0 -113,0
36	55	34	4 Hjerter	N 10	620	113,0 -113,0
8	91	1	4 Hjerter	N 10	620	113,0 -113,0
28	30	75	4 Hjerter	N 10	620	113,0 -113,0
24	33	14	4 Hjerter	N 10	620	113,0 -113,0
5	64	78	4 Hjerter	N 10	620	113,0 -113,0
6	50	28	4 Hjerter	N 10	620	113,0 -113,0
18	10	93	4 Spar	N 10	620	113,0 -113,0
34	2	69	3 Hjerter	N 11	200	-280,0 280,0
44	72	76	3 Hjerter	N 10	170	-312,0 312,0
12	17	57	3 Hjerter	N 10	170	-312,0 312,0
43	70	61	1 NT	N 8	120	-360,0 360,0
2	88	13	3 NT	N 8	100	-468,0 468,0
4	60	46	4 Hjerter	N 9	100	-468,0 468,0
29	19	24	4 Hjerter	N 9	100	-468,0 468,0
3	81	53	4 Hjerter	N 9	100	-468,0 468,0
46	62	63	4 Hjerter	N 9	100	-468,0 468,0
27	43	49	4 Hjerter	N 9	100	-468,0 468,0
39	77	42	4 Hjerter	N 9	100	-468,0 468,0

# IMP, 05. august 2010

Mappern: **30(30)**  
Rundenr: **10**

Øst / Ingen

♠ T3  
♥ KT4  
♦ J8532  
♣ JT8

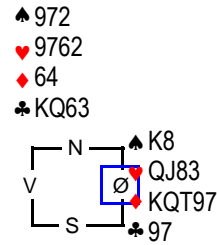

♠ AQJ654  
♥ A5  
♦ A  
♣ A542

Bord	NS	ØV	NS	ØV	NS	ØV
7	38	87	5 Ruter D	Ø 8	500	108,0 -108,0
35	51	18	4 Spar	S 12	480	66,0 -66,0
13	9	44	4 Spar	S 12	480	66,0 -66,0
3	81	53	4 Spar	S 12	480	66,0 -66,0
1	16	37	4 Spar	S 12	480	66,0 -66,0
25	59	23	4 Spar	S 12	480	66,0 -66,0
15	80	26	4 Spar	S 12	480	66,0 -66,0
45	21	67	4 Spar	S 12	480	66,0 -66,0
41	5	54	4 Spar	S 12	480	66,0 -66,0
36	55	34	4 Spar	S 12	480	66,0 -66,0
9	86	20	4 Spar	S 12	480	66,0 -66,0
11	40	11	4 Spar	S 12	480	66,0 -66,0
10	27	66	4 Spar	S 12	480	66,0 -66,0
28	30	75	4 Spar	S 12	480	66,0 -66,0
5	64	78	4 Spar	S 12	480	66,0 -66,0
4	60	46	4 Spar	S 12	480	66,0 -66,0
39	77	42	4 Spar	S 12	480	66,0 -66,0
12	17	57	4 Spar	S 12	480	66,0 -66,0
24	33	14	4 Spar	S 12	480	66,0 -66,0
20	25	85	4 Spar	S 12	480	66,0 -66,0
42	52	12	4 Spar	S 12	480	66,0 -66,0
34	2	69	4 Spar	S 12	480	66,0 -66,0
21	6	74	4 Spar	S 12	480	66,0 -66,0
6	50	28	4 Spar	S 12	480	66,0 -66,0
31	68	4	4 Spar	S 12	480	66,0 -66,0
30	3	58	4 Spar	S 12	480	66,0 -66,0
23	31	39	4 Spar	S 12	480	66,0 -66,0
27	43	49	4 Spar	S 12	480	66,0 -66,0
14	45	84	4 Spar	S 12	480	66,0 -66,0
26	22	82	5 Spar	S 12	480	66,0 -66,0
8	91	1	5 Spar	S 12	480	66,0 -66,0
2	88	13	5 Spar	S 12	480	66,0 -66,0
43	70	61	4 Spar	S 11	450	24,0 -24,0
44	72	76	4 Spar	S 11	450	24,0 -24,0
40	65	73	4 Spar	S 11	450	24,0 -24,0
22	29	32	4 Spar	S 11	450	24,0 -24,0
46	62	63	4 Spar	S 11	450	24,0 -24,0
32	56	7	4 Ruter D	Ø 8	300	-161,0 161,0
38	15	41	5 Ruter D	Ø 9	300	-161,0 161,0
19	92	90	3 Spar	S 13	260	-208,0 208,0
18	10	93	1 Spar	N 12	230	-223,0 223,0
47	48	35	2 Spar	S 12	230	-223,0 223,0
37	94	47	2 Spar	S 12	230	-223,0 223,0
33	8	89	3 Spar	S 12	230	-223,0 223,0
17	36	83	3 Spar	S 12	230	-223,0 223,0
16	79	71	2 Spar	S 11	200	-264,0 264,0
29	19	24	4 Ruter	Ø 8	100	-365,0 365,0

# SPILLSTENSILER

Mappnr: 31(31)

Rundenr: 11

Syd / N/S

- ♠ 765
- ♥ 9532
- ♦ Q932
- ♣ AT

♠ 3

♥ KT

♦ T654

♣ QJ9654

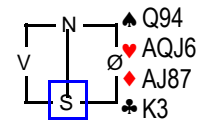

♠ AKJT82

♥ 874

♦ K

♣ 872

Bord	NS	ØV	NS	ØV	NS	ØV
40	47	54	2 Spar	S 11	200	244,0 -244,0
37	2	15	2 Spar	S 10	170	206,0 -206,0
12	17	32	2 Spar	S 10	170	206,0 -206,0
14	9	84	2 Spar	S 10	170	206,0 -206,0
3	53	46	2 Spar	S 10	170	206,0 -206,0
15	45	92	3 NT	Ø 6	150	186,0 -186,0
16	38	33	3 NT	Ø 6	150	186,0 -186,0
47	35	62	2 Spar	N 9	140	177,0 -177,0
7	27	86	2 Spar	N 8	110	138,0 -138,0
33	8	59	2 Spar	S 8	110	138,0 -138,0
18	85	1	3 Kløver	N 9	110	138,0 -138,0
11	57	10	3 Kløver	N 9	110	138,0 -138,0
13	90	66	2 NT	Ø 6	100	134,0 -134,0
19	11	36	2 NT	Ø 6	100	134,0 -134,0
9	40	80	4 Hjerter	V 8	100	134,0 -134,0
42	61	21	4 Hjerter	V 8	100	134,0 -134,0
32	34	29	4 Hjerter	V 8	100	134,0 -134,0
6	28	64	4 Hjerter	V 8	100	134,0 -134,0
43	67	41	2 NT	Ø 7	50	66,0 -66,0
10	44	20	2 NT	Ø 7	50	66,0 -66,0
8	50	91	3 Hjerter	V 8	50	66,0 -66,0
30	42	58	3 Hjerter	V 8	50	66,0 -66,0
17	83	25	3 Hjerter	V 8	50	66,0 -66,0
46	52	48	4 Hjerter	Ø 9	50	66,0 -66,0
26	3	94	4 Hjerter	V 9	50	66,0 -66,0
25	74	49	4 Hjerter	V 9	50	66,0 -66,0
22	26	68	4 Hjerter	V 9	50	66,0 -66,0
2	37	88	4 Hjerter	Ø 9	50	66,0 -66,0
24	24	79	2 Spar	S 7	100	100,0 -100,0
44	76	65	2 Spar	S 7	100	100,0 -100,0
1	16	81	2 Spar	S 7	100	100,0 -100,0
34	7	55	2 Spar	S 7	100	100,0 -100,0
29	82	71	3 Ruter	Ø 9	110	106,0 -106,0
27	93	30	3 Hjerter	V 9	140	144,0 -144,0
23	23	51	3 Hjerter	V 9	140	144,0 -144,0
45	73	63	3 Hjerter	V 9	140	144,0 -144,0
31	75	31	3 Hjerter	V 9	140	144,0 -144,0
21	14	6	3 Hjerter	V 9	140	144,0 -144,0
4	13	87	2 NT	Ø 9	150	152,0 -152,0
28	56	39	3 Hjerter	V 10	170	188,0 -188,0
39	5	72	3 Hjerter	V 10	170	188,0 -188,0
5	60	78	3 Hjerter	V 10	170	188,0 -188,0
41	12	70	3 NT	N 7	200	211,0 -211,0
36	89	4	2 NT	Ø 11	210	216,0 -216,0
20	19	22	3 NT	Ø 9	400	394,0 -394,0
38	69	43	4 Hjerter	V 10	420	408,0 -408,0
35	18	77	3 Spar D	S 7	500	462,0 -462,0

# IMP, 05. august 2010

Mappnr: 32(32)

Rundenr: 11

Vest / Ø/V

- ♠ 7653
- ♥ KT6
- ♦ Q98
- ♣ J42

♠ AJ

♥ J

♦ JT76432

♣ 953

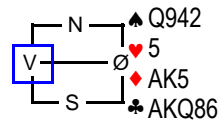

♠ KT8

♥ AQ987432

♦

♣ T7

Bord	NS	ØV	NS	ØV	NS	ØV
44	76	65	5 Hjerter D	S 11	650	258,0 -258,0
8	50	91	3 Hjerter D	S 10	630	225,0 -225,0
31	75	31	3 Hjerter D	S 10	630	225,0 -225,0
21	14	6	4 Hjerter D	S 10	590	187,0 -187,0
2	37	88	4 Hjerter D	S 10	590	187,0 -187,0
19	11	36	4 Hjerter D	S 10	590	187,0 -187,0
33	8	59	4 Hjerter D	S 10	590	187,0 -187,0
26	3	94	4 Hjerter D	S 10	590	187,0 -187,0
3	53	46	4 Hjerter D	S 10	590	187,0 -187,0
38	69	43	4 Hjerter D	S 10	590	187,0 -187,0
23	23	51	4 Hjerter D	S 10	590	187,0 -187,0
34	7	55	4 Hjerter D	S 10	590	187,0 -187,0
18	85	1	4 Hjerter D	S 10	590	187,0 -187,0
4	13	87	4 Hjerter D	S 10	590	187,0 -187,0
14	9	84	4 Hjerter D	S 10	590	187,0 -187,0
7	27	86	4 Hjerter D	S 10	590	187,0 -187,0
25	74	49	4 Hjerter D	S 10	590	187,0 -187,0
30	42	58	4 Hjerter D	S 10	590	187,0 -187,0
41	12	70	4 Hjerter D	S 10	590	187,0 -187,0
15	45	92	4 Hjerter D	S 10	590	187,0 -187,0
5	60	78	4 Hjerter D	S 10	590	187,0 -187,0
35	18	77	4 Hjerter D	S 10	590	187,0 -187,0
28	56	39	4 Hjerter D	S 10	590	187,0 -187,0
17	83	25	4 Hjerter D	S 10	590	187,0 -187,0
20	19	22	4 Hjerter D	S 10	590	187,0 -187,0
16	38	33	5 Kløver D	Ø 9	500	81,0 -81,0
45	73	63	4 Hjerter	S 10	420	3,0 -3,0
37	2	15	4 Hjerter	S 10	420	3,0 -3,0
12	17	32	4 Hjerter	S 10	420	3,0 -3,0
42	61	21	4 Hjerter	S 10	420	3,0 -3,0
11	57	10	5 Ruter	V 7	400	-15,0 15,0
22	26	68	6 Spar	V 8	400	-15,0 15,0
39	5	72	5 Spar	V 8	300	-110,0 110,0
46	52	48	4 Spar	Ø 8	200	-210,0 210,0
10	44	20	4 Spar	V 8	200	-210,0 210,0
43	67	41	3 NT	Ø 8	100	-287,0 287,0
47	35	62	3 NT	Ø 8	100	-287,0 287,0
29	82	71	4 Spar	Ø 9	100	-287,0 287,0
24	24	79	4 Spar	Ø 9	100	-287,0 287,0
6	28	64	4 Spar	V 9	100	-287,0 287,0
36	89	4	4 Spar	V 9	100	-287,0 287,0
27	93	30	4 Spar	V 9	100	-287,0 287,0
13	90	66	4 Hjerter D	S 9	100	-426,0 426,0
40	47	54	4 Hjerter D	S 9	100	-426,0 426,0
1	16	81	4 Hjerter D	S 9	100	-426,0 426,0
9	40	80	5 Hjerter D	S 10	100	-426,0 426,0
32	34	29	3 NT	Ø 9	600	-642,0 642,0



# SPILLSTENSILER

Mappenr: 1(33)

Rundenr: 11

Nord / Ingen

♠ AQ76432

♥ Q7

♦ T

♣ JT6

♠ T9

♥ AJ2

♦ QJ764

♣ 542

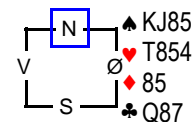

♠

♥ K963

♦ AK932

♣ AK93

Bord	NS	ØV	NS	ØV	NS	ØV
3	53	46	6 Ruter	N 13	940	450,0 -450,0
47	35	62	6 Ruter	S 12	920	428,0 -428,0
37	2	15	6 Ruter	S 12	920	428,0 -428,0
33	8	59	6 Ruter	S 12	920	428,0 -428,0
44	76	65	6 Ruter	S 12	920	428,0 -428,0
18	85	1	6 Ruter	N 12	920	428,0 -428,0
36	89	4	6 Ruter	S 12	920	428,0 -428,0
39	5	72	6 Spar D	V 8	800	336,0 -336,0
5	60	78	4 Spar D	V 7	500	45,0 -45,0
34	7	55	5 Spar D	V 8	500	45,0 -45,0
16	38	33	5 Spar D	V 8	500	45,0 -45,0
43	67	41	5 Spar D	V 8	500	45,0 -45,0
4	13	87	5 Ruter	S 13	440	-17,0 17,0
42	61	21	5 Ruter	S 13	440	-17,0 17,0
31	75	31	5 Ruter	S 13	440	-17,0 17,0
7	27	86	5 Ruter	S 13	440	-17,0 17,0
38	69	43	5 Ruter	S 13	440	-17,0 17,0
27	93	30	5 Ruter	S 13	440	-17,0 17,0
40	47	54	5 Ruter	S 13	440	-17,0 17,0
11	57	10	5 Ruter	S 13	440	-17,0 17,0
46	52	48	5 Ruter	S 13	440	-17,0 17,0
29	82	71	4 Hjerter	S 10	420	-55,0 55,0
28	56	39	5 Ruter	S 12	420	-55,0 55,0
41	12	70	5 Ruter	S 12	420	-55,0 55,0
32	34	29	5 Ruter	S 12	420	-55,0 55,0
21	14	6	5 Ruter	S 12	420	-55,0 55,0
23	23	51	5 Ruter	S 12	420	-55,0 55,0
15	45	92	5 Ruter	S 12	420	-55,0 55,0
22	26	68	5 Ruter	S 12	420	-55,0 55,0
20	19	22	5 Ruter	S 12	420	-55,0 55,0
10	44	20	5 Ruter	N 12	420	-55,0 55,0
19	11	36	5 Ruter	S 12	420	-55,0 55,0
13	90	66	5 Ruter	S 12	420	-55,0 55,0
30	42	58	5 Ruter	S 12	420	-55,0 55,0
2	37	88	5 Ruter	S 12	420	-55,0 55,0
24	24	79	5 Ruter	S 12	420	-55,0 55,0
12	17	32	5 Ruter	S 11	400	-78,0 78,0
6	28	64	5 Ruter	S 11	400	-78,0 78,0
9	40	80	4 Spar D	V 8	300	-179,0 179,0
26	3	94	4 Spar D	Ø 8	300	-179,0 179,0
14	9	84	4 Spar D	V 8	300	-179,0 179,0
25	74	49	4 Ruter	S 13	190	-283,0 283,0
1	16	81	4 Ruter	S 12	170	-312,0 312,0
45	73	63	4 Ruter	S 12	170	-312,0 312,0
35	18	77	4 Ruter	S 12	170	-312,0 312,0
8	50	91	4 Ruter	S 12	170	-312,0 312,0
17	83	25	5 Spar	V 8	150	-332,0 332,0

# IMP, 05. august 2010

Mappenr: 2(34)

Rundenr: 12

Øst / N/S

♠ Q9764

♥ 5

♦ AKJ832

♣ 7

♠ 5

♥ AKQ9742

♦ 976

♣ KJ

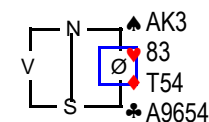

♠ JT82

♥ JT6

♦ Q

♣ QT832

Bord	NS	ØV	NS	ØV	NS	ØV
45	70	63	4 Hjerter D	N 10	790	663,0 -663,0
4	78	86	4 Hjerter D	N 10	790	663,0 -663,0
20	74	11	4 Hjerter	N 10	620	610,0 -610,0
26	39	82	4 Spar	V 8	100	432,0 -432,0
40	69	41	6 Spar	V 11	50	415,0 -415,0
6	28	80	4 Ruter	V 12	170	246,0 -246,0
25	30	17	3 Spar	V 11	200	206,0 -206,0
1	13	16	3 Spar	Ø 11	200	206,0 -206,0
37	61	23	5 Ruter	V 11	400	27,0 -27,0
27	31	14	5 Ruter	V 11	400	27,0 -27,0
33	55	93	4 Spar	V 11	450	-47,0 47,0
3	37	53	4 Spar	V 11	450	-47,0 47,0
24	56	3	4 Spar	Ø 11	450	-47,0 47,0
32	71	36	4 Spar	V 11	450	-47,0 47,0
41	77	54	4 Spar	V 11	450	-47,0 47,0
12	83	33	4 Spar	V 11	450	-47,0 47,0
7	57	27	4 Spar	V 11	450	-47,0 47,0
22	79	20	4 Spar	Ø 11	450	-47,0 47,0
11	10	92	4 Spar	Ø 11	450	-47,0 47,0
2	46	88	4 Spar	V 11	450	-47,0 47,0
5	81	87	4 Spar	V 11	450	-47,0 47,0
43	35	47	4 Spar	V 11	450	-47,0 47,0
14	84	66	4 Spar	V 11	450	-47,0 47,0
34	18	8	4 Spar	V 11	450	-47,0 47,0
46	67	62	4 Spar	V 11	450	-47,0 47,0
10	50	40	4 Spar	V 11	450	-47,0 47,0
19	85	42	4 Spar	V 11	450	-47,0 47,0
39	65	52	4 Spar	V 11	450	-47,0 47,0
13	32	68	4 Spar	V 11	450	-47,0 47,0
15	45	38	4 Spar	V 11	450	-47,0 47,0
18	25	90	4 Spar	Ø 11	450	-47,0 47,0
21	94	22	4 Spar	V 11	450	-47,0 47,0
38	15	5	4 Spar	Ø 11	450	-47,0 47,0
31	34	2	4 Spar	V 11	450	-47,0 47,0
36	21	76	4 Spar	V 11	450	-47,0 47,0
9	64	91	4 Spar	V 11	450	-47,0 47,0
29	6	19	4 Spar	V 11	450	-47,0 47,0
8	60	9	4 Spar	V 11	450	-47,0 47,0
35	7	26	5 Spar	V 11	450	-47,0 47,0
16	49	24	5 Hjerter D	N 9	500	-121,0 121,0
47	48	73	5 Spar D	V 11	650	-258,0 258,0
23	44	51	5 Spar D	Ø 11	650	-258,0 258,0
44	72	12	4 Spar D	V 11	690	-299,0 299,0
30	29	89	4 Spar D	V 11	690	-299,0 299,0
42	4	43	4 Spar D	V 11	690	-299,0 299,0
17	1	59	4 Spar D	Ø 11	690	-299,0 299,0
28	75	58	4 Spar D	V 11	690	-299,0 299,0

# SPILLSTENSILER

Mappennr: **3(35)**  
Rundenr: **12**

Syd / ØV

- ♠ AQJ752
- ♥ KT76
- ♦ J6
- ♣ T

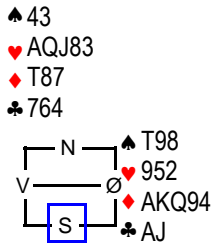

Bord	NS	ØV		NS	ØV	NS	ØV
23	44	51	5 Spar	V 10	100	587,0	-587,0
28	75	58	6 Spar	V 11	100	587,0	-587,0
12	83	33	6 Spar	V 11	100	587,0	-587,0
14	84	66	6 Spar	V 11	100	587,0	-587,0
37	61	23	5 Kløver	S 7	200	434,0	-434,0
39	65	52	5 Kløver D	S 9	300	383,0	-383,0
10	50	40	5 Kløver D	S 8	500	227,0	-227,0
13	32	68	3 NT	Ø 10	630	116,0	-116,0
3	37	53	3 NT	Ø 10	630	116,0	-116,0
7	57	27	5 Spar	V 11	650	82,0	-82,0
38	15	5	5 Spar	V 11	650	82,0	-82,0
30	29	89	5 Spar	V 11	650	82,0	-82,0
25	30	17	4 Spar	V 12	680	50,0	-50,0
42	4	43	4 Spar	V 12	680	50,0	-50,0
9	64	91	4 Spar	V 12	680	50,0	-50,0
16	49	24	4 Spar	V 12	680	50,0	-50,0
36	21	76	4 Spar	V 12	680	50,0	-50,0
5	81	87	4 Spar	V 12	680	50,0	-50,0
40	69	41	4 Spar	V 12	680	50,0	-50,0
35	7	26	4 Spar	V 12	680	50,0	-50,0
2	46	88	5 Spar	V 12	680	50,0	-50,0
32	71	36	5 Spar	V 12	680	50,0	-50,0
31	34	2	5 Spar	V 12	680	50,0	-50,0
27	31	14	5 Spar	V 12	680	50,0	-50,0
29	6	19	5 Spar	V 12	680	50,0	-50,0
17	1	59	5 Spar	V 12	680	50,0	-50,0
11	10	92	5 Spar	V 12	680	50,0	-50,0
33	55	93	5 Spar	V 12	680	50,0	-50,0
6	28	80	5 Spar	V 12	680	50,0	-50,0
15	45	38	5 Spar	V 12	680	50,0	-50,0
20	74	11	5 Spar	V 12	680	50,0	-50,0
45	70	63	5 Spar	V 12	680	50,0	-50,0
47	48	73	5 Spar	V 12	680	50,0	-50,0
44	72	12	5 Spar	V 12	680	50,0	-50,0
21	94	22	5 Spar	V 12	680	50,0	-50,0
8	60	9	5 Spar	V 12	680	50,0	-50,0
46	67	62	5 Kløver D	S 7	800	-60,0	60,0
1	13	16	6 Spar	V 12	1430	-500,0	500,0
4	78	86	6 Spar	V 12	1430	-500,0	500,0
24	56	3	6 Spar	V 12	1430	-500,0	500,0
34	18	8	6 Spar	V 12	1430	-500,0	500,0
19	85	42	6 Spar	V 12	1430	-500,0	500,0
43	35	47	6 Spar	V 12	1430	-500,0	500,0
41	77	54	6 Spar	V 12	1430	-500,0	500,0
26	39	82	6 Spar	V 12	1430	-500,0	500,0
22	79	20	6 Spar	V 12	1430	-500,0	500,0
18	25	90	6 Spar	V 13	1460	-510,0	510,0

# IMP, 05. august 2010

Mappennr: **4(36)**  
Rundenr: **12**

Vest / Alle

- ♠ A943
- ♥ KJT
- ♦ 9763
- ♣ Q2

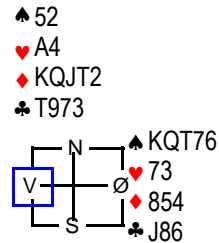

Bord	NS	ØV		NS	ØV	NS	ØV
24	56	3	4 Spar D	Ø 6	1100	623,0	-623,0
32	71	36	4 Hjerter D	S 10	790	483,0	-483,0
14	84	66	3 Hjerter D	S 9	730	450,0	-450,0
3	37	53	4 Hjerter	S 11	650	413,0	-413,0
8	60	9	4 Hjerter	S 11	650	413,0	-413,0
21	94	22	4 Hjerter	S 10	620	379,0	-379,0
11	10	92	4 Hjerter	S 10	620	379,0	-379,0
12	83	33	4 Hjerter	S 10	620	379,0	-379,0
33	55	93	4 Hjerter	S 10	620	379,0	-379,0
23	44	51	4 Hjerter	S 10	620	379,0	-379,0
43	35	47	4 Hjerter	N 10	620	379,0	-379,0
30	29	89	4 Spar D	V 8	500	311,0	-311,0
18	25	90	2 Hjerter	S 11	200	58,0	-58,0
40	69	41	3 Spar	Ø 7	200	58,0	-58,0
41	77	54	2 Hjerter	S 10	170	34,0	-34,0
27	31	14	2 Hjerter	S 10	170	34,0	-34,0
39	65	52	2 Hjerter	S 10	170	34,0	-34,0
29	6	19	2 Hjerter	S 10	170	34,0	-34,0
35	7	26	3 Hjerter	S 10	170	34,0	-34,0
46	67	62	2 Hjerter	S 9	140	-2,0	2,0
7	57	27	2 Hjerter	S 9	140	-2,0	2,0
2	46	88	3 Hjerter	S 9	140	-2,0	2,0
42	4	43	3 Hjerter	S 9	140	-2,0	2,0
16	49	24	3 Hjerter	S 9	140	-2,0	2,0
31	34	2	3 Ruter	N 10	130	-4,0	4,0
45	70	63	2 Ruter	N 9	110	-45,0	45,0
25	30	17	3 Ruter	N 9	110	-45,0	45,0
1	13	16	4 Hjerter	S 9	100	-229,0	229,0
9	64	91	4 Hjerter	S 9	100	-229,0	229,0
17	1	59	4 Hjerter	S 9	100	-229,0	229,0
19	85	42	4 Hjerter	S 9	100	-229,0	229,0
38	15	5	4 Hjerter	S 9	100	-229,0	229,0
26	39	82	4 Hjerter	S 9	100	-229,0	229,0
6	28	80	4 Hjerter	S 9	100	-229,0	229,0
44	72	12	4 Hjerter	S 9	100	-229,0	229,0
15	45	38	4 Hjerter	S 9	100	-229,0	229,0
22	79	20	4 Hjerter	S 9	100	-229,0	229,0
37	61	23	4 Hjerter	S 9	100	-229,0	229,0
28	75	58	4 Hjerter	S 9	100	-229,0	229,0
20	74	11	4 Hjerter	S 9	100	-229,0	229,0
13	32	68	4 Hjerter	S 9	100	-229,0	229,0
4	78	86	4 Kløver	S 9	100	-229,0	229,0
10	50	40	3 Ruter	N 7	200	-327,0	327,0
47	48	73	4 Hjerter	S 8	200	-327,0	327,0
36	21	76	5 Kløver	S 9	200	-327,0	327,0
5	81	87	5 Kløver	S 9	200	-327,0	327,0
34	18	8	5 Kløver	S 8	300	-406,0	406,0

# SPILLSTENSILER

Mappennr: **5(37)**  
Rundenr: **13**

Nord / N/S

- ♠ AQ32
- ♥ KT43
- ♦ JT5
- ♣ 83

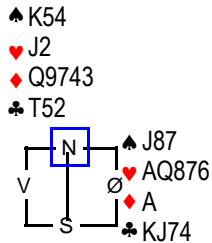

- ♠ T96
- ♥ 95
- ♦ K862
- ♣ AQ96

Bord	NS	ØV		NS	ØV	NS	ØV
32	58	1	6 Hjerter	Ø 10	100	493,0	-493,0
2	16	78	5 Hjerter	Ø 10	50	445,0	-445,0
21	2	74	2 Hjerter	Ø 10	170	252,0	-252,0
45	70	73	4 Hjerter	Ø 10	420	-26,0	26,0
18	42	22	4 Hjerter	Ø 10	420	-26,0	26,0
5	88	57	4 Hjerter	Ø 10	420	-26,0	26,0
36	21	34	4 Hjerter	Ø 10	420	-26,0	26,0
43	15	72	4 Hjerter	Ø 10	420	-26,0	26,0
6	87	46	4 Hjerter	Ø 10	420	-26,0	26,0
12	66	45	4 Hjerter	Ø 10	420	-26,0	26,0
40	54	52	4 Hjerter	Ø 10	420	-26,0	26,0
22	8	29	4 Hjerter	Ø 10	420	-26,0	26,0
30	59	77	4 Hjerter	Ø 10	420	-26,0	26,0
13	38	68	4 Hjerter	Ø 10	420	-26,0	26,0
37	23	5	4 Hjerter	V 10	420	-26,0	26,0
39	43	35	4 Hjerter	Ø 10	420	-26,0	26,0
27	75	6	4 Hjerter	Ø 10	420	-26,0	26,0
17	11	33	4 Hjerter	Ø 10	420	-26,0	26,0
23	51	71	4 Hjerter	Ø 10	420	-26,0	26,0
46	62	12	4 Hjerter	Ø 10	420	-26,0	26,0
41	4	69	4 Hjerter	Ø 10	420	-26,0	26,0
8	28	85	4 Hjerter	Ø 10	420	-26,0	26,0
26	39	44	4 Hjerter	Ø 10	420	-26,0	26,0
29	76	31	4 Hjerter	Ø 10	420	-26,0	26,0
4	13	27	4 Hjerter	Ø 10	420	-26,0	26,0
11	50	83	4 Hjerter	Ø 10	420	-26,0	26,0
31	89	7	4 Hjerter	Ø 10	420	-26,0	26,0
34	61	26	4 Hjerter	Ø 10	420	-26,0	26,0
9	64	60	4 Hjerter	Ø 10	420	-26,0	26,0
25	90	56	4 Hjerter	Ø 10	420	-26,0	26,0
28	14	3	4 Hjerter	Ø 10	420	-26,0	26,0
24	24	17	4 Hjerter	Ø 10	420	-26,0	26,0
16	49	94	4 Hjerter	Ø 10	420	-26,0	26,0
7	86	9	4 Hjerter	Ø 10	420	-26,0	26,0
19	25	84	4 Hjerter	Ø 10	420	-26,0	26,0
10	91	10	4 Hjerter	Ø 10	420	-26,0	26,0
1	53	80	4 Hjerter	Ø 10	420	-26,0	26,0
44	65	47	4 Hjerter	Ø 10	420	-26,0	26,0
3	37	81	4 Hjerter	Ø 10	420	-26,0	26,0
20	20	30	4 Hjerter	Ø 10	420	-26,0	26,0
33	19	82	4 Hjerter	Ø 10	420	-26,0	26,0
47	67	48	4 Hjerter	Ø 10	420	-26,0	26,0
42	63	18	4 Hjerter	Ø 10	420	-26,0	26,0
35	36	55	4 Hjerter	Ø 10	420	-26,0	26,0
14	40	32	4 Hjerter	Ø 10	420	-26,0	26,0
15	92	79	4 Hjerter	Ø 10	420	-26,0	26,0
38	41	93	4 Hjerter	Ø 11	450	-72,0	72,0

# IMP, 05. august 2010

Mappennr: **6(38)**  
Rundenr: **13**

Øst / Ø/V

- ♠ KQ
- ♥ 9754
- ♦ K85
- ♣ AQ54

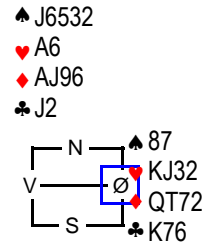

- ♠ AT94
- ♥ QT8
- ♦ 43
- ♣ T983

Bord	NS	ØV		NS	ØV	NS	ØV
9	64	60	3 Spar D	N 9	530	458,0	-458,0
20	20	30	4 Hjerter	V 8	200	172,0	-172,0
16	49	94	4 Hjerter	V 8	200	172,0	-172,0
28	14	3	4 Hjerter	V 8	200	172,0	-172,0
18	42	22	4 Hjerter	V 8	200	172,0	-172,0
45	70	73	4 Hjerter	V 8	200	172,0	-172,0
46	62	12	4 Hjerter	V 8	200	172,0	-172,0
39	43	35	4 Kløver	V 8	200	172,0	-172,0
27	75	6	2 Spar	N 9	140	97,0	-97,0
6	87	46	2 Spar	N 9	140	97,0	-97,0
43	15	72	2 Spar	N 9	140	97,0	-97,0
30	59	77	3 Spar	N 9	140	97,0	-97,0
32	58	1	3 Spar	N 9	140	97,0	-97,0
11	50	83	3 Spar	N 9	140	97,0	-97,0
12	66	45	3 Spar	N 9	140	97,0	-97,0
22	8	29	3 Spar	N 9	140	97,0	-97,0
41	4	69	3 Spar	N 9	140	97,0	-97,0
31	89	7	3 Spar	N 9	140	97,0	-97,0
21	2	74	3 Spar	N 9	140	97,0	-97,0
13	38	68	3 Spar	N 9	140	97,0	-97,0
5	88	57	3 Spar	N 9	140	97,0	-97,0
33	19	82	3 Spar	N 9	140	97,0	-97,0
24	24	17	3 Spar	N 9	140	97,0	-97,0
1	53	80	2 Spar	S 8	110	52,0	-52,0
15	92	79	2 Spar	N 8	110	52,0	-52,0
17	11	33	2 Spar	N 8	110	52,0	-52,0
4	13	27	2 Spar	N 8	110	52,0	-52,0
8	28	85	1 NT	V 6	100	50,0	-50,0
7	86	9	4 Hjerter	V 9	100	50,0	-50,0
37	23	5	3 Spar	N 8	50	-116,0	116,0
3	37	81	3 Spar	N 8	50	-116,0	116,0
35	36	55	3 Spar	N 8	50	-116,0	116,0
40	54	52	3 Spar	S 8	50	-116,0	116,0
29	76	31	3 Spar	N 8	50	-116,0	116,0
2	16	78	3 Spar	N 8	50	-116,0	116,0
19	25	84	3 Spar	N 7	100	-180,0	180,0
38	41	93	4 Spar D	N 9	100	-180,0	180,0
26	39	44	2 Hjerter	V 8	110	-184,0	184,0
23	51	71	2 Hjerter	Ø 9	140	-226,0	226,0
47	67	48	2 Hjerter	Ø 9	140	-226,0	226,0
36	21	34	3 Hjerter	V 9	140	-226,0	226,0
25	90	56	3 Hjerter	V 9	140	-226,0	226,0
44	65	47	3 Hjerter	V 9	140	-226,0	226,0
34	61	26	3 Hjerter	V 9	140	-226,0	226,0
42	63	18	3 Hjerter	V 9	140	-226,0	226,0
10	91	10	3 Hjerter	V 9	140	-226,0	226,0
14	40	32	4 Spar D	N 8	300	-377,0	377,0

# SPILLSTENSILER

Mappennr: **7(39)**  
Rundenr: **13**

Syd / Alle

♠ J  
♥ K96  
♦ KJ63  
♣ JT932

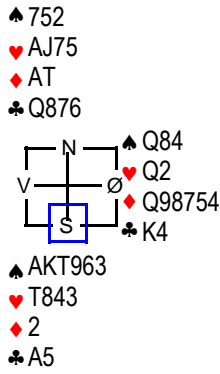

Bord	NS	ØV	NS	ØV	NS	ØV
17	11	33	4 Hjerter	S 12	680	225,0 -225,0
15	92	79	4 Hjerter	S 11	650	189,0 -189,0
23	51	71	4 Hjerter	S 11	650	189,0 -189,0
29	76	31	4 Hjerter	S 11	650	189,0 -189,0
9	64	60	4 Hjerter	S 11	650	189,0 -189,0
13	38	68	4 Hjerter	S 11	650	189,0 -189,0
5	88	57	4 Hjerter	S 11	650	189,0 -189,0
4	13	27	4 Hjerter	S 11	650	189,0 -189,0
20	20	30	4 Spar	S 11	650	189,0 -189,0
30	59	77	4 Spar	S 11	650	189,0 -189,0
12	66	45	4 Spar	S 11	650	189,0 -189,0
11	50	83	4 Spar	S 11	650	189,0 -189,0
16	49	94	4 Spar	S 11	650	189,0 -189,0
39	43	35	4 Spar	S 11	650	189,0 -189,0
38	41	93	4 Spar	S 11	650	189,0 -189,0
21	2	74	4 Spar	S 11	650	189,0 -189,0
46	62	12	4 Spar	S 11	650	189,0 -189,0
35	36	55	4 Spar	S 11	650	189,0 -189,0
41	4	69	4 Hjerter	S 10	620	148,0 -148,0
22	8	29	4 Hjerter	S 10	620	148,0 -148,0
6	87	46	4 Hjerter	S 10	620	148,0 -148,0
8	28	85	4 Spar	S 10	620	148,0 -148,0
40	54	52	4 Spar	S 10	620	148,0 -148,0
3	37	81	4 Spar	S 10	620	148,0 -148,0
7	86	9	4 Spar	S 10	620	148,0 -148,0
33	19	82	4 Spar	S 10	620	148,0 -148,0
24	24	17	4 Spar	S 10	620	148,0 -148,0
1	53	80	4 Spar	S 10	620	148,0 -148,0
25	90	56	4 Spar	S 10	620	148,0 -148,0
32	58	1	4 Spar	S 10	620	148,0 -148,0
31	89	7	4 Spar	S 10	620	148,0 -148,0
42	63	18	4 Spar	S 10	620	148,0 -148,0
26	39	44	3 Spar	S 11	200	-238,0 238,0
34	61	26	2 Spar	S 10	170	-260,0 260,0
47	67	48	2 Spar	S 10	170	-260,0 260,0
43	15	72	2 Spar	S 10	170	-260,0 260,0
45	70	73	3 Hjerter	S 10	170	-260,0 260,0
10	91	10	2 Spar	S 9	140	-292,0 292,0
19	25	84	3 Spar	S 9	140	-292,0 292,0
44	65	47	4 Hjerter	S 9	100	-443,0 443,0
37	23	5	4 Hjerter	S 9	100	-443,0 443,0
18	42	22	4 Spar	S 9	100	-443,0 443,0
27	75	6	4 Spar	S 9	100	-443,0 443,0
28	14	3	4 Spar	S 9	100	-443,0 443,0
14	40	32	4 Spar	S 9	100	-443,0 443,0
2	16	78	4 Hjerter	S 8	200	-495,0 495,0
36	21	34	4 Hjerter	S 8	200	-495,0 495,0

# IMP, 05. august 2010

Mappennr: **8(40)**  
Rundenr: **14**

Vest / Ingen

♠ 65  
♥ JT93  
♦ 98752  
♣ 62

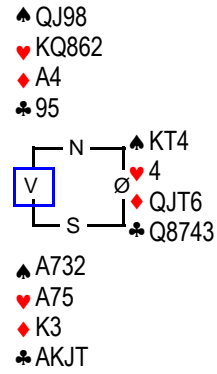

Bord	NS	ØV	NS	ØV	NS	ØV
37	70	23	5 Kløver D	Ø 4	1700	661,0 -661,0
22	22	11	6 Hjerter	N 12	980	258,0 -258,0
32	54	89	6 Hjerter	N 12	980	258,0 -258,0
33	58	5	6 Hjerter	N 12	980	258,0 -258,0
24	56	66	6 NT	S 12	990	258,0 -258,0
38	77	21	6 NT	S 12	990	258,0 -258,0
7	27	60	6 NT	S 12	990	258,0 -258,0
28	55	6	6 NT	S 12	990	258,0 -258,0
39	36	1	6 NT	S 12	990	258,0 -258,0
42	41	47	6 Spar	S 12	980	258,0 -258,0
2	80	37	6 Spar	S 12	980	258,0 -258,0
8	57	28	6 Spar	S 12	980	258,0 -258,0
17	71	30	6 Spar	S 12	980	258,0 -258,0
44	52	15	6 Spar	S 12	980	258,0 -258,0
10	10	42	6 Spar	S 12	980	258,0 -258,0
29	82	14	6 Spar	S 12	980	258,0 -258,0
11	64	20	6 Spar	S 12	980	258,0 -258,0
1	87	16	6 Spar	S 12	980	258,0 -258,0
12	9	38	6 Spar	S 12	980	258,0 -258,0
18	94	32	6 Spar	S 12	980	258,0 -258,0
21	92	24	6 Spar	S 12	980	258,0 -258,0
23	59	76	6 Spar	S 12	980	258,0 -258,0
45	62	72	6 Spar	S 12	980	258,0 -258,0
19	90	49	6 Spar	S 12	980	258,0 -258,0
31	7	61	6 Spar	S 12	980	258,0 -258,0
26	79	75	6 Spar	S 12	980	258,0 -258,0
9	84	91	6 Spar	S 12	980	258,0 -258,0
13	8	50	4 Spar	S 12	480	-122,0 122,0
16	45	44	5 Spar	S 12	480	-122,0 122,0
6	46	83	5 Spar	S 12	480	-122,0 122,0
27	17	31	5 Spar	N 12	480	-122,0 122,0
4	81	88	6 Hjerter	N 11	50	-410,0 410,0
15	85	74	6 Hjerter	N 11	50	-410,0 410,0
3	53	86	6 Hjerter	N 11	50	-410,0 410,0
5	78	13	6 Hjerter	N 11	50	-410,0 410,0
40	35	65	6 Hjerter	N 11	50	-410,0 410,0
14	68	40	6 Hjerter	N 11	50	-410,0 410,0
47	63	67	6 Hjerter	N 11	50	-410,0 410,0
41	93	4	6 Hjerter	N 11	50	-410,0 410,0
20	29	2	6 Hjerter	N 11	50	-410,0 410,0
43	12	73	6 NT	S 11	50	-410,0 410,0
30	33	39	6 NT	N 11	50	-410,0 410,0
35	26	69	6 Spar	S 11	50	-410,0 410,0
46	48	18	7 Hjerter	N 11	100	-441,0 441,0
34	51	19	7 Hjerter	N 11	100	-441,0 441,0
25	3	25	7 Hjerter	N 11	100	-441,0 441,0
36	43	34	7 NT D	S 10	500	-638,0 638,0

# SPILLSTENSILER

Mappenr: **9(41)**  
Rundenr: **14**

Nord / ØV

- ♠ K9865
- ♥ A432
- ♦ 4
- ♣ T93

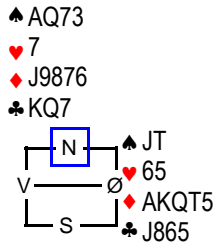

- ♠ 42
- ♥ KQJT98
- ♦ 32
- ♣ A42

Bord	NS	ØV	NS	ØV	NS	ØV
45	62	72	4 Spar D	V 6	1100	
44	52	15	4 Hjerter D	S 10	590	249,0 -249,0
36	43	34	4 Hjerter D	S 10	590	249,0 -249,0
41	93	4	3 NT D	N 9	550	210,0 -210,0
1	87	16	1 NT D	Ø 5	500	145,0 -145,0
2	80	37	3 NT	N 11	460	102,0 -102,0
14	68	40	3 NT	N 10	430	62,0 -62,0
43	12	73	3 NT	N 10	430	62,0 -62,0
35	26	69	3 NT	S 10	430	62,0 -62,0
38	77	21	3 NT	N 10	430	62,0 -62,0
18	94	32	3 NT	N 10	430	62,0 -62,0
40	35	65	4 Hjerter	S 10	420	58,0 -58,0
42	41	47	4 Hjerter	S 10	420	58,0 -58,0
19	90	49	4 Hjerter	S 10	420	58,0 -58,0
9	84	91	4 Hjerter	S 10	420	58,0 -58,0
7	27	60	4 Hjerter	S 10	420	58,0 -58,0
5	78	13	4 Hjerter	S 10	420	58,0 -58,0
21	92	24	4 Hjerter	S 10	420	58,0 -58,0
25	3	25	4 Hjerter	S 10	420	58,0 -58,0
34	51	19	4 Hjerter	S 10	420	58,0 -58,0
3	53	86	4 Hjerter	S 10	420	58,0 -58,0
32	54	89	4 Hjerter	S 10	420	58,0 -58,0
8	57	28	4 Hjerter	S 10	420	58,0 -58,0
39	36	1	4 Hjerter	S 10	420	58,0 -58,0
20	29	2	4 Hjerter	S 10	420	58,0 -58,0
12	9	38	3 NT	N 9	400	23,0 -23,0
30	33	39	3 NT	N 9	400	23,0 -23,0
28	55	6	3 NT	N 9	400	23,0 -23,0
31	7	61	3 NT	N 9	400	23,0 -23,0
13	8	50	3 NT	N 9	400	23,0 -23,0
17	71	30	3 NT	N 9	400	23,0 -23,0
47	63	67	3 NT	N 9	400	23,0 -23,0
29	82	14	3 NT	N 9	400	23,0 -23,0
23	59	76	3 NT	N 9	400	23,0 -23,0
27	17	31	3 NT	N 9	400	23,0 -23,0
15	85	74	3 Kløver	Ø 6	300	-86,0 86,0
37	70	23	3 Kløver	Ø 7	200	-201,0 201,0
33	58	5	2 Hjerter	S 10	170	-225,0 225,0
46	48	18	2 Hjerter	S 10	170	-225,0 225,0
6	46	83	2 Hjerter	S 10	170	-225,0 225,0
16	45	44	3 Hjerter	S 10	170	-225,0 225,0
22	22	11	3 Hjerter	S 10	170	-225,0 225,0
24	56	66	3 Hjerter	S 10	170	-225,0 225,0
26	79	75	3 Hjerter	S 9	140	-258,0 258,0
4	81	88	3 Hjerter	S 9	140	-258,0 258,0
10	10	42	3 Hjerter	S 9	140	-258,0 258,0
11	64	20	4 Hjerter	S 8	100	-469,0 469,0

# IMP, 05. august 2010

Mappenr: **10(42)**  
Rundenr: **14**

Øst / Alle

- ♠ AT73
- ♥ K6
- ♦ 9874
- ♣ Q85

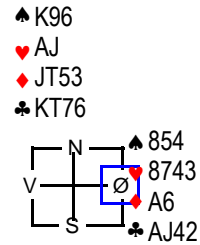

- ♠ KJ2
- ♥ QT952
- ♦ KQ2
- ♣ 93

Bord	NS	ØV	NS	ØV	NS	ØV
29	82	14	3 NT	N 10	630	457,0 -457,0
1	87	16	3 NT	N 10	630	457,0 -457,0
42	41	47	3 NT	N 9	600	437,0 -437,0
7	27	60	3 NT	S 9	600	437,0 -437,0
41	93	4	1 NT D	N 9	580	419,0 -419,0
19	90	49	2 Spar	V 6	200	63,0 -63,0
14	68	40	2 Spar	Ø 6	200	63,0 -63,0
31	7	61	2 Spar	V 6	200	63,0 -63,0
40	35	65	1 NT	N 10	180	42,0 -42,0
37	70	23	2 Hjerter	N 10	170	38,0 -38,0
28	55	6	1 Hjerter	S 9	140	-3,0 3,0
35	26	69	1 NT	N 9	150	-3,0 3,0
25	3	25	1 NT	N 9	150	-3,0 3,0
23	59	76	1 NT	N 9	150	-3,0 3,0
47	63	67	1 NT	N 9	150	-3,0 3,0
44	52	15	1 NT	N 9	150	-3,0 3,0
13	8	50	2 Hjerter	S 9	140	-3,0 3,0
6	46	83	2 Hjerter	S 9	140	-3,0 3,0
36	43	34	2 Hjerter	S 9	140	-3,0 3,0
20	29	2	2 Hjerter	S 9	140	-3,0 3,0
9	84	91	2 NT	N 9	150	-3,0 3,0
24	56	66	2 NT	N 9	150	-3,0 3,0
2	80	37	2 NT	N 9	150	-3,0 3,0
38	77	21	2 NT	S 9	150	-3,0 3,0
45	62	72	1 NT	N 8	120	-44,0 44,0
12	9	38	1 NT	N 8	120	-44,0 44,0
11	64	20	1 NT	N 8	120	-44,0 44,0
39	36	1	1 NT	N 8	120	-44,0 44,0
17	71	30	1 NT	N 8	120	-44,0 44,0
46	48	18	1 NT	N 8	120	-44,0 44,0
30	33	39	1 NT	N 8	120	-44,0 44,0
22	22	11	2 NT	N 8	120	-44,0 44,0
43	12	73	2 NT	N 8	120	-44,0 44,0
8	57	28	2 Hjerter	S 8	110	-47,0 47,0
16	45	44	2 Hjerter	S 8	110	-47,0 47,0
33	58	5	1 NT	N 7	90	-77,0 77,0
32	54	89	1 NT	N 7	90	-77,0 77,0
27	17	31	Pass		-179,0 179,0	
18	94	32	Pass		-179,0 179,0	
34	51	19	Pass		-179,0 179,0	
26	79	75	Pass		-179,0 179,0	
10	10	42	Pass		-179,0 179,0	
4	81	88	Pass		-179,0 179,0	
15	85	74	Pass		-179,0 179,0	
21	92	24	Pass		-179,0 179,0	
3	53	86	Pass		-179,0 179,0	
5	78	13	Pass		-179,0 179,0	

# SPILLSTENSILER

Mappennr: 11(43)

Rundenr: 15

Syd / Ingen

♠ Q8763  
♥ K97  
♦ J9  
♣ A85

♠ AK5  
♥ 3  
♦ AK742  
♣ T943

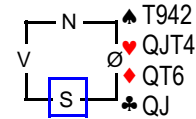

♠ J  
♥ A8652  
♦ 853  
♣ K762

Bord	NS	ØV	NS	ØV	NS	ØV
3	78	53	3 NT	N 9	400	369,0 -369,0
47	72	48	3 Spar D	Ø 7	300	271,0 -271,0
35	26	43	3 Spar D	V 7	300	271,0 -271,0
8	60	57	3 Spar D	V 7	300	271,0 -271,0
10	10	64	2 Kløver	N 11	150	109,0 -109,0
6	46	86	3 Kløver	S 11	150	109,0 -109,0
34	5	51	2 Ruter	S 10	130	83,0 -83,0
24	56	79	2 Ruter	S 10	130	83,0 -83,0
7	91	27	3 Kløver	S 10	130	83,0 -83,0
17	30	44	3 Kløver	N 10	130	83,0 -83,0
20	90	2	3 Kløver	N 10	130	83,0 -83,0
39	36	65	3 Kløver	N 10	130	83,0 -83,0
29	82	33	3 Kløver	S 10	130	83,0 -83,0
4	81	13	3 Ruter	S 10	130	83,0 -83,0
31	7	54	4 Kløver	S 10	130	83,0 -83,0
21	92	22	4 Kløver	N 10	130	83,0 -83,0
43	12	18	2 NT	N 8	120	78,0 -78,0
16	71	45	2 Ruter	N 9	110	51,0 -51,0
13	38	50	3 Kløver	S 9	110	51,0 -51,0
5	88	83	3 Kløver	N 9	110	51,0 -51,0
14	68	85	3 Kløver	S 9	110	51,0 -51,0
23	11	76	3 Kløver	N 9	110	51,0 -51,0
19	32	49	2 Spar D	V 7	100	45,0 -45,0
44	52	63	3 Spar D	Ø 8	100	45,0 -45,0
45	15	67	3 Spar D	V 8	100	45,0 -45,0
1	16	80	1 NT	N 7	90	35,0 -35,0
26	25	75	2 Spar	V 7	50	-15,0 15,0
42	4	41	2 Spar	V 7	50	-15,0 15,0
11	42	20	2 Spar	V 7	50	-15,0 15,0
30	14	39	2 Spar	V 7	50	-15,0 15,0
25	66	3	3 Spar	V 8	50	-15,0 15,0
33	58	19	2 Hjerter	S 7	50	-134,0 134,0
32	61	89	2 Hjerter	N 7	50	-134,0 134,0
41	47	93	2 Hjerter	N 7	50	-134,0 134,0
12	9	8	2 NT	N 7	50	-134,0 134,0
9	28	84	3 Kløver	N 8	50	-134,0 134,0
37	21	70	5 Kløver	S 10	50	-134,0 134,0
28	31	55	5 Kløver	N 10	50	-134,0 134,0
18	94	29	5 Kløver	N 10	50	-134,0 134,0
15	40	74	3 NT	N 7	100	-197,0 197,0
2	37	87	3 NT	N 7	100	-197,0 197,0
40	1	35	5 Kløver	N 9	100	-197,0 197,0
46	73	62	5 Kløver	S 9	100	-197,0 197,0
38	23	77	5 Kløver	S 9	100	-197,0 197,0
36	69	34	5 Kløver	N 9	100	-197,0 197,0
22	24	59	2 Spar	V 8	110	-202,0 202,0
27	17	6	2 Spar	V 8	110	-202,0 202,0

# IMP, 05. august 2010

Mappennr: 12(44)

Rundenr: 15

Vest / N/S

♠ QJ954  
♥ 75  
♦ T4  
♣ JT54

♠ AT2  
♥ KQ962  
♦ 83  
♣ AKQ

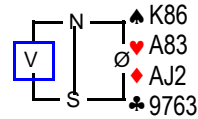

♠ 73  
♥ JT4  
♦ KQ9765  
♣ 82

Bord	NS	ØV	NS	ØV	NS	ØV
21	92	22	4 Hjerter	N 11	650	142,0 -142,0
44	52	63	4 Hjerter	N 11	650	142,0 -142,0
18	94	29	4 Hjerter	N 11	650	142,0 -142,0
34	5	51	4 Hjerter	N 11	650	142,0 -142,0
11	42	20	4 Hjerter	N 11	650	142,0 -142,0
42	4	41	4 Hjerter	N 11	650	142,0 -142,0
45	15	67	4 Hjerter	N 11	650	142,0 -142,0
33	58	19	4 Hjerter	N 11	650	142,0 -142,0
39	36	65	4 Hjerter	N 11	650	142,0 -142,0
19	32	49	4 Hjerter	N 11	650	142,0 -142,0
23	11	76	4 Hjerter	N 11	650	142,0 -142,0
3	78	53	4 Hjerter	N 11	650	142,0 -142,0
4	81	13	4 Hjerter	N 11	650	142,0 -142,0
9	28	84	4 Hjerter	N 10	620	98,0 -98,0
10	10	64	4 Hjerter	N 10	620	98,0 -98,0
37	21	70	4 Hjerter	N 10	620	98,0 -98,0
20	90	2	4 Hjerter	N 10	620	98,0 -98,0
7	91	27	4 Hjerter	N 10	620	98,0 -98,0
1	16	80	4 Hjerter	N 10	620	98,0 -98,0
2	37	87	4 Hjerter	N 10	620	98,0 -98,0
38	23	77	4 Hjerter	N 10	620	98,0 -98,0
26	25	75	4 Hjerter	N 10	620	98,0 -98,0
14	68	85	4 Hjerter	N 10	620	98,0 -98,0
29	82	33	4 Hjerter	N 10	620	98,0 -98,0
36	69	34	4 Hjerter	N 10	620	98,0 -98,0
13	38	50	4 Hjerter	N 10	620	98,0 -98,0
46	73	62	4 Hjerter	N 10	620	98,0 -98,0
30	14	39	4 Hjerter	N 10	620	98,0 -98,0
5	88	83	4 Hjerter	N 10	620	98,0 -98,0
12	9	8	4 Hjerter	N 10	620	98,0 -98,0
47	72	48	4 Hjerter	N 10	620	98,0 -98,0
16	71	45	4 Hjerter	N 10	620	98,0 -98,0
15	40	74	4 Hjerter	N 10	620	98,0 -98,0
24	56	79	3 NT	N 9	600	61,0 -61,0
28	31	55	3 NT	S 9	600	61,0 -61,0
41	47	93	3 NT	S 9	600	61,0 -61,0
17	30	44	4 Spar D	V 7	500	-29,0 29,0
35	26	43	3 Spar D	V 7	300	-235,0 235,0
8	60	57	2 Hjerter	N 11	200	-313,0 313,0
25	66	3	1 Hjerter	N 10	170	-343,0 343,0
22	24	59	3 Hjerter	N 10	170	-343,0 343,0
27	17	6	2 NT	N 9	150	-365,0 365,0
6	46	86	3 Ruter	S 11	150	-365,0 365,0
32	61	89	3 NT	N 8	100	-499,0 499,0
31	7	54	4 Hjerter	N 9	100	-499,0 499,0
40	1	35	4 Hjerter	N 9	100	-499,0 499,0
43	12	18	4 Spar	N 9	100	-499,0 499,0

# SPILLSTENSILER

Mappern: **13(45)**  
Rundenr: **15**

Nord / Alle

♠ KJT763  
♥ A42  
♦ A63  
♣ Q

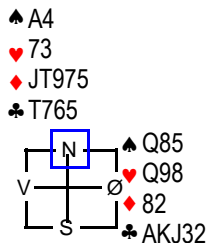

♠ 92  
♥ KJT65  
♦ KQ4  
♣ 984

Bord	NS	ØV		NS	ØV	NS	ØV
42	4	41	6 Spar	V 10	200	593,0	-593,0
23	11	76	6 Spar	Ø 10	200	593,0	-593,0
44	52	63	4 Spar	V 10	620	42,0	-42,0
3	78	53	4 Spar	V 10	620	42,0	-42,0
47	72	48	4 Spar	V 10	620	42,0	-42,0
9	28	84	4 Spar	V 10	620	42,0	-42,0
40	1	35	4 Spar	V 10	620	42,0	-42,0
45	15	67	4 Spar	V 10	620	42,0	-42,0
17	30	44	4 Spar	Ø 11	650	-1,0	1,0
20	90	2	4 Spar	V 11	650	-1,0	1,0
21	92	22	4 Spar	V 11	650	-1,0	1,0
15	40	74	4 Spar	V 11	650	-1,0	1,0
26	25	75	4 Spar	V 11	650	-1,0	1,0
24	56	79	4 Spar	V 11	650	-1,0	1,0
25	66	3	4 Spar	V 11	650	-1,0	1,0
38	23	77	4 Spar	V 11	650	-1,0	1,0
29	82	33	4 Spar	V 11	650	-1,0	1,0
35	26	43	4 Spar	V 11	650	-1,0	1,0
1	16	80	4 Spar	V 11	650	-1,0	1,0
6	46	86	4 Spar	V 11	650	-1,0	1,0
18	94	29	4 Spar	V 11	650	-1,0	1,0
2	37	87	4 Spar	V 11	650	-1,0	1,0
11	42	20	4 Spar	Ø 11	650	-1,0	1,0
7	91	27	4 Spar	Ø 11	650	-1,0	1,0
34	5	51	4 Spar	V 11	650	-1,0	1,0
8	60	57	4 Spar	V 11	650	-1,0	1,0
13	38	50	4 Spar	V 11	650	-1,0	1,0
39	36	65	4 Spar	V 11	650	-1,0	1,0
46	73	62	4 Spar	V 11	650	-1,0	1,0
43	12	18	4 Spar	V 11	650	-1,0	1,0
37	21	70	4 Spar	Ø 11	650	-1,0	1,0
41	47	93	4 Spar	Ø 11	650	-1,0	1,0
27	17	6	4 Spar	V 11	650	-1,0	1,0
16	71	45	4 Spar	V 11	650	-1,0	1,0
28	31	55	4 Spar	V 11	650	-1,0	1,0
14	68	85	4 Spar	V 11	650	-1,0	1,0
36	69	34	4 Spar	V 11	650	-1,0	1,0
31	7	54	4 Spar	V 11	650	-1,0	1,0
33	58	19	4 Spar	V 11	650	-1,0	1,0
5	88	83	5 Spar	V 11	650	-1,0	1,0
32	61	89	4 Spar	V 12	680	-44,0	44,0
30	14	39	4 Spar	V 12	680	-44,0	44,0
12	9	8	4 Spar	V 12	680	-44,0	44,0
19	32	49	4 Spar	V 12	680	-44,0	44,0
4	81	13	5 Spar	V 12	680	-44,0	44,0
10	10	64	6 Spar	Ø 12	1430	-593,0	593,0
22	24	59	6 Spar	Ø 12	1430	-593,0	593,0

# IMP, 05. august 2010

Mappern: **14(46)**  
Rundenr: **16**

Øst / Ingen

♠ AJ987  
♥ 9862  
♦ J5  
♣ J4

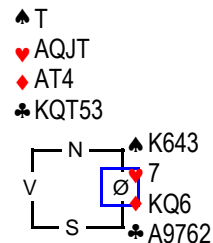

♠ T  
♥ AQJT  
♦ AT4  
♣ KQT53

Bord	NS	ØV		NS	ØV	NS	ØV
22	66	82	4 Spar D	V 7	500	566,0	-566,0
20	94	40	4 Spar D	V 8	300	463,0	-463,0
15	74	90	4 Hjerter	Ø 6	200	407,0	-407,0
17	92	60	4 Spar D	Ø 9	100	333,0	-333,0
21	34	24	3 Spar	V 8	50	290,0	-290,0
27	85	3	4 Spar	V 9	50	290,0	-290,0
45	48	21	4 Spar	Ø 9	50	290,0	-290,0
32	39	89	3 Ruter	S 8	50	202,0	-202,0
39	61	14	4 Hjerter	S 9	50	202,0	-202,0
12	2	50	4 Ruter	S 9	50	202,0	-202,0
44	67	12	4 Ruter	S 9	50	202,0	-202,0
2	87	86	3 Hjerter	S 7	100	144,0	-144,0
4	13	80	4 Hjerter	S 8	100	144,0	-144,0
34	69	79	4 Hjerter	S 8	100	144,0	-144,0
26	30	55	2 Spar	V 8	110	137,0	-137,0
6	16	10	2 Spar	V 9	140	107,0	-107,0
7	57	20	3 Spar	Ø 9	140	107,0	-107,0
43	35	23	3 Spar	Ø 9	140	107,0	-107,0
16	59	91	3 Spar	V 9	140	107,0	-107,0
28	6	76	2 Spar	Ø 10	170	70,0	-70,0
24	19	31	3 Spar	V 10	170	70,0	-70,0
10	32	64	3 Spar	Ø 10	170	70,0	-70,0
46	1	15	3 Spar	V 10	170	70,0	-70,0
36	43	77	3 Spar	Ø 10	170	70,0	-70,0
31	7	70	3 Spar	V 10	170	70,0	-70,0
30	54	75	3 Spar	V 10	170	70,0	-70,0
37	93	52	2 Spar	V 11	200	45,0	-45,0
29	25	29	3 Spar	V 11	200	45,0	-45,0
11	46	8	5 Ruter D	S 9	300	-62,0	62,0
40	18	4	4 Spar	V 10	420	-175,0	175,0
23	58	56	4 Spar	V 10	420	-175,0	175,0
47	63	72	4 Spar	V 10	420	-175,0	175,0
3	84	37	4 Spar	Ø 10	420	-175,0	175,0
9	78	28	4 Spar	V 10	420	-175,0	175,0
1	88	27	4 Spar	V 10	420	-175,0	175,0
42	65	62	4 Hjerter D	S 7	500	-247,0	247,0
18	49	11	5 Hjerter D	S 8	500	-247,0	247,0
41	73	47	3 Spar D	V 9	530	-274,0	274,0
25	5	45	4 Spar D	V 10	590	-333,0	333,0
19	22	68	4 Spar D	V 10	590	-333,0	333,0
14	38	71	4 Spar D	V 10	590	-333,0	333,0
38	33	51	4 Spar D	Ø 10	590	-333,0	333,0
35	41	36	4 Spar D	V 10	590	-333,0	333,0
33	26	17	4 Spar D	V 10	590	-333,0	333,0
8	44	81	4 Spar D	V 10	590	-333,0	333,0
13	42	9	4 Spar D	V 10	590	-333,0	333,0
5	83	53	5 Hjerter D	N 7	800	-480,0	480,0

# SPILLSTENSILER

Mappenr: 15(47)

Rundenr: 16

Syd / N/S

- ♠ AJ83
- ♥ T8764
- ♦ AK
- ♣ 93

♠ Q74

♥ J5

♦ 72

♣ QT8752

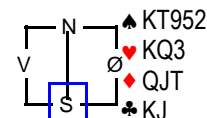

♠ 6

♥ A92

♦ 986543

♣ A64

Bord	NS	ØV	NS	ØV	NS	ØV
43	35	23	6 Spar D	Ø 10	300	525,0 -525,0
23	58	56	5 Hjerter	V 9	100	437,0 -437,0
39	61	14	4 Spar	Ø 9	50	398,0 -398,0
22	66	82	4 Spar	Ø 9	50	398,0 -398,0
27	85	3	5 Spar	Ø 10	50	398,0 -398,0
8	44	81	5 Spar	Ø 10	50	398,0 -398,0
33	26	17	5 Spar	Ø 10	50	398,0 -398,0
17	92	60	5 Spar	Ø 10	50	398,0 -398,0
37	93	52	4 Hjerter	V 10	420	-64,0 64,0
47	63	72	4 Hjerter	V 10	420	-64,0 64,0
10	32	64	4 Spar	Ø 10	420	-64,0 64,0
9	78	28	4 Spar	Ø 10	420	-64,0 64,0
46	1	15	4 Spar	Ø 10	420	-64,0 64,0
45	48	21	4 Spar	Ø 10	420	-64,0 64,0
30	54	75	4 Spar	Ø 10	420	-64,0 64,0
26	30	55	4 Spar	Ø 10	420	-64,0 64,0
41	73	47	4 Spar	Ø 10	420	-64,0 64,0
35	41	36	4 Spar	Ø 10	420	-64,0 64,0
7	57	20	4 Spar	Ø 10	420	-64,0 64,0
13	42	9	4 Spar	Ø 10	420	-64,0 64,0
15	74	90	4 Spar	Ø 10	420	-64,0 64,0
40	18	4	4 Spar	Ø 10	420	-64,0 64,0
19	22	68	4 Spar	V 10	420	-64,0 64,0
11	46	8	4 Spar	Ø 10	420	-64,0 64,0
38	33	51	4 Spar	Ø 10	420	-64,0 64,0
31	7	70	4 Spar	V 10	420	-64,0 64,0
4	13	80	4 Spar	Ø 10	420	-64,0 64,0
18	49	11	4 Spar	Ø 10	420	-64,0 64,0
1	88	27	4 Spar	Ø 10	420	-64,0 64,0
12	2	50	4 Spar	Ø 10	420	-64,0 64,0
21	34	24	4 Spar	Ø 10	420	-64,0 64,0
20	94	40	4 Hjerter	V 11	450	-109,0 109,0
44	67	12	4 Hjerter	V 11	450	-109,0 109,0
28	6	76	4 Hjerter	V 11	450	-109,0 109,0
29	25	29	4 Hjerter	V 11	450	-109,0 109,0
2	87	86	4 Spar	Ø 11	450	-109,0 109,0
24	19	31	4 Spar	Ø 11	450	-109,0 109,0
14	38	71	4 Spar	Ø 11	450	-109,0 109,0
3	84	37	4 Spar	Ø 11	450	-109,0 109,0
34	69	79	4 Spar	Ø 11	450	-109,0 109,0
6	16	10	4 Spar	Ø 11	450	-109,0 109,0
5	83	53	4 Spar	Ø 11	450	-109,0 109,0
25	5	45	5 Hjerter	V 11	450	-109,0 109,0
42	65	62	5 Spar	Ø 11	450	-109,0 109,0
16	59	91	4 Hjerter	V 12	480	-148,0 148,0
36	43	77	4 Spar	Ø 12	480	-148,0 148,0
32	39	89	2 Ruter D	S 6	500	-165,0 165,0

# IMP, 05. august 2010

Mappenr: 16(48)

Rundenr: 16

Vest / Ø/V

- ♠ JT72
- ♥ 953
- ♦ K
- ♣ 98652

♠ 654

♥ T2

♦ Q876

♣ AQ43

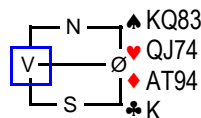

♠ A9

♥ AK86

♦ J532

♣ JT7

Bord	NS	ØV	NS	ØV	NS	ØV
18	49	11	2 NT D	Ø 6	500	436,0 -436,0
38	33	51	2 Ruter D	Ø 6	500	436,0 -436,0
22	66	82	1 Ruter	Ø 4	300	274,0 -274,0
25	5	45	1 Ruter	Ø 5	200	174,0 -174,0
32	39	89	1 Ruter	Ø 5	200	174,0 -174,0
12	2	50	1 Ruter	Ø 5	200	174,0 -174,0
26	30	55	1 Ruter	Ø 5	200	174,0 -174,0
43	35	23	2 Hjerter	Ø 6	200	174,0 -174,0
39	61	14	3 NT	Ø 7	200	174,0 -174,0
44	67	12	3 Spar	V 7	200	174,0 -174,0
15	74	90	1 Hjerter	Ø 6	100	55,0 -55,0
46	1	15	1 NT	Ø 6	100	55,0 -55,0
27	85	3	1 NT	Ø 6	100	55,0 -55,0
30	54	75	1 Ruter	Ø 6	100	55,0 -55,0
29	25	29	1 Ruter	Ø 6	100	55,0 -55,0
16	59	91	1 Ruter	Ø 6	100	55,0 -55,0
47	63	72	1 Ruter	Ø 6	100	55,0 -55,0
41	73	47	1 Ruter	Ø 6	100	55,0 -55,0
3	84	37	2 Hjerter	Ø 7	100	55,0 -55,0
28	6	76	2 Spar	Ø 7	100	55,0 -55,0
17	92	60	3 Spar	V 8	100	55,0 -55,0
9	78	28	3 Spar	V 8	100	55,0 -55,0
6	16	10	1 NT	N 7	90	54,0 -54,0
4	13	80	1 NT	S 7	90	54,0 -54,0
14	38	71	1 NT	N 7	90	54,0 -54,0
36	43	77	1 NT	N 7	90	54,0 -54,0
45	48	21	1 NT	N 7	90	54,0 -54,0
35	41	36	1 NT	N 7	90	54,0 -54,0
1	88	27	1 NT	N 6	50	-112,0 112,0
7	57	20	1 NT	N 6	50	-112,0 112,0
11	46	8	1 NT	N 6	50	-112,0 112,0
24	19	31	1 Spar	V 7	80	-156,0 156,0
40	18	4	1 NT	Ø 7	90	-159,0 159,0
8	44	81	1 NT	Ø 7	90	-159,0 159,0
19	22	68	1 NT	Ø 7	90	-159,0 159,0
42	65	62	1 NT	Ø 7	90	-159,0 159,0
13	42	9	2 Ruter	Ø 8	90	-159,0 159,0
5	83	53	3 Kløver	N 7	100	-169,0 169,0
33	26	17	3 NT	S 7	100	-169,0 169,0
23	58	56	2 Hjerter	Ø 8	110	-177,0 177,0
31	7	70	2 Spar	V 8	110	-177,0 177,0
21	34	24	2 Spar	V 8	110	-177,0 177,0
20	94	40	2 Spar	Ø 8	110	-177,0 177,0
37	93	52	1 NT	Ø 8	120	-198,0 198,0
34	69	79	2 Hjerter	S 5	150	-224,0 224,0
2	87	86	3 NT	S 6	150	-224,0 224,0
10	32	64	3 Kløver D	N 7	300	-369,0 369,0



# SPILLSTENSILER

Mappnr: 17(49)

Rundenr: 17

Nord / Ingen

- ♠ 8
- ♥ K765
- ♦ 95
- ♣ J97542

♠ QJ52

♥ T942

♦ AT4

♣ AK

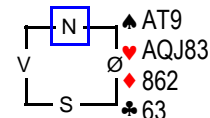

♠ K7643

♥

♦ KQJ73

♣ QT8

Bord	NS	ØV		NS	ØV	NS	ØV
45	72	67	6 Spar D	S 12	1210	495,0	-495,0
14	9	46	6 Spar	S 12	980	394,0	-394,0
17	90	91	6 Spar	N 12	980	394,0	-394,0
19	60	82	6 Spar	N 12	980	394,0	-394,0
37	76	93	6 Spar	N 12	980	394,0	-394,0
27	55	25	6 Spar	S 12	980	394,0	-394,0
32	36	79	6 Spar	S 12	980	394,0	-394,0
21	56	49	6 Spar	N 12	980	394,0	-394,0
36	43	24	6 Spar	S 12	980	394,0	-394,0
47	1	48	6 Spar	S 12	980	394,0	-394,0
40	14	73	4 Spar D	S 12	790	212,0	-212,0
1	88	84	4 Spar	S 12	480	-81,0	81,0
9	20	28	4 Spar	S 12	480	-81,0	81,0
38	17	35	4 Spar	S 12	480	-81,0	81,0
15	71	2	4 Spar	N 12	480	-81,0	81,0
41	62	51	4 Spar	S 12	480	-81,0	81,0
29	66	85	4 Spar	S 12	480	-81,0	81,0
8	83	59	4 Spar	S 12	480	-81,0	81,0
28	45	29	4 Spar	S 12	480	-81,0	81,0
20	34	94	4 Spar	S 12	480	-81,0	81,0
42	47	61	4 Spar	S 12	480	-81,0	81,0
34	77	4	4 Spar	N 12	480	-81,0	81,0
16	74	92	4 Spar	S 12	480	-81,0	81,0
43	65	23	4 Spar	S 12	480	-81,0	81,0
7	53	57	4 Spar	N 12	480	-81,0	81,0
6	80	81	4 Spar	S 12	480	-81,0	81,0
23	40	58	4 Spar	N 12	480	-81,0	81,0
44	21	15	4 Spar	S 12	480	-81,0	81,0
26	31	30	4 Spar	S 12	480	-81,0	81,0
2	87	27	4 Spar	S 12	480	-81,0	81,0
5	64	16	4 Spar	N 12	480	-81,0	81,0
35	52	18	4 Spar	N 12	480	-81,0	81,0
3	86	13	4 Spar	S 12	480	-81,0	81,0
11	32	42	4 Spar	S 12	480	-81,0	81,0
46	12	63	4 Spar	S 12	480	-81,0	81,0
31	70	26	4 Spar	S 12	480	-81,0	81,0
30	75	39	4 Spar	N 12	480	-81,0	81,0
4	37	78	4 Spar	S 12	480	-81,0	81,0
13	11	50	4 Spar	S 12	480	-81,0	81,0
12	8	38	5 Spar	N 12	480	-81,0	81,0
25	89	19	5 Spar	N 12	480	-81,0	81,0
10	44	10	5 Spar	N 12	480	-81,0	81,0
24	22	54	2 Spar	S 11	200	-345,0	345,0
39	33	41	3 Kløver D	Ø 8	100	-420,0	420,0
18	68	6	4 Hjerter D	Ø 9	100	-420,0	420,0
22	3	5	3 Hjerter	Ø 9	140	-557,0	557,0
33	69	7	24 Spar	N 9	50	46,0	46,0

# IMP, 05. august 2010

Mappnr: 18(50)

Rundenr: 17

Øst / N/S

- ♠ Q2
- ♥ AKQ9
- ♦ KJ973
- ♣ 63

♠ 964

♥ T85

♦ T2

♣ AKJ72

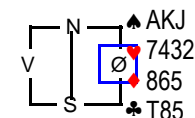

♠ T8753

♥ J6

♦ AQ4

♣ Q94

Bord	NS	ØV		NS	ØV	NS	ØV
11	32	42	3 NT	V 7	100	273,0	-273,0
43	65	23	3 NT	Ø 7	100	273,0	-273,0
47	1	48	4 Hjerter	Ø 8	100	273,0	-273,0
12	8	38	4 Hjerter	Ø 9	50	220,0	-220,0
7	53	57	4 Hjerter	Ø 9	50	220,0	-220,0
39	33	41	4 Hjerter	Ø 9	50	220,0	-220,0
32	36	79	4 Hjerter	Ø 9	50	220,0	-220,0
18	68	6	1 NT	V 7	90	61,0	-61,0
6	80	81	1 NT	V 7	90	61,0	-61,0
38	17	35	1 NT	V 7	90	61,0	-61,0
35	52	18	1 NT	V 7	90	61,0	-61,0
19	60	82	1 NT	V 7	90	61,0	-61,0
1	88	84	1 NT	Ø 7	90	61,0	-61,0
16	74	92	1 NT	V 7	90	61,0	-61,0
42	47	61	1 NT	V 7	90	61,0	-61,0
34	77	4	1 NT	V 7	90	61,0	-61,0
13	11	50	1 NT	V 7	90	61,0	-61,0
21	56	49	1 NT	V 7	90	61,0	-61,0
3	86	13	1 NT	V 7	90	61,0	-61,0
30	75	39	1 NT	V 7	90	61,0	-61,0
28	45	29	3 Ruter	V 9	110	31,0	-31,0
8	83	59	1 NT	V 8	120	18,0	-18,0
17	90	91	1 NT	V 8	120	18,0	-18,0
2	87	27	1 NT	V 8	120	18,0	-18,0
33	69	7	1 NT	V 8	120	18,0	-18,0
40	14	73	2 Hjerter	Ø 9	140	-12,0	12,0
44	21	15	2 Hjerter	V 9	140	-12,0	12,0
9	20	28	2 Hjerter	Ø 9	140	-12,0	12,0
14	9	46	2 Hjerter	V 9	140	-12,0	12,0
45	72	67	3 Hjerter	V 9	140	-12,0	12,0
4	37	78	3 Hjerter	Ø 9	140	-12,0	12,0
24	22	54	3 Hjerter	Ø 9	140	-12,0	12,0
41	62	51	3 Spar	Ø 9	140	-12,0	12,0
10	44	10	2 Hjerter	Ø 10	170	-45,0	45,0
5	64	16	2 Hjerter	Ø 10	170	-45,0	45,0
15	71	2	3 Hjerter	Ø 10	170	-45,0	45,0
20	34	94	2 Hjerter	Ø 11	200	-76,0	76,0
36	43	24	2 Spar D	S 7	200	-76,0	76,0
25	89	19	3 Hjerter	Ø 11	200	-76,0	76,0
29	66	85	3 Kløver	N 7	200	-76,0	76,0
37	76	93	3 Spar	S 7	200	-76,0	76,0
23	40	58	4 Hjerter	V 10	420	-312,0	312,0
26	31	30	4 Hjerter	V 10	420	-312,0	312,0
46	12	63	4 Hjerter	Ø 10	420	-312,0	312,0
31	70	26	4 Hjerter	Ø 10	420	-312,0	312,0
27	55	25	4 Hjerter	Ø 12	480	-362,0	362,0
22	3	5	3 Spar D	N 7	500	-374,0	374,0

# SPILLSTENSILER

Mappen: **19(51)**  
Rundenr: **17**

Syd / ØV

- ♠ 982
- ♥ AK93
- ♦ 653
- ♣ QJ2

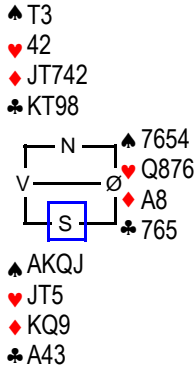

Bord	NS	ØV			NS	ØV	NS	ØV
43	65	23	2 Spar D	S 9	570		488,0	-488,0
31	70	26	3 Hjerter D	V 7	500		435,0	-435,0
47	1	48	3 NT	S 11	460		423,0	-423,0
10	44	10	3 NT	S 11	460		423,0	-423,0
39	33	41	3 NT	S 11	460		423,0	-423,0
11	32	42	3 NT	S 10	430		378,0	-378,0
37	76	93	3 NT	S 10	430		378,0	-378,0
29	66	85	1 Kløver	S 11	150		129,0	-129,0
5	64	16	2 NT	S 8	120		119,0	-119,0
35	52	18	2 NT	S 8	120		119,0	-119,0
19	60	82	2 NT	S 8	120		119,0	-119,0
33	69	7	1 Kløver	S 9	110		82,0	-82,0
3	86	13	3 NT	S 8		50	-97,0	97,0
30	75	39	3 NT	S 8		50	-97,0	97,0
42	47	61	3 NT	S 8		50	-97,0	97,0
6	80	81	3 NT	S 8		50	-97,0	97,0
23	40	58	3 NT	S 8		50	-97,0	97,0
38	17	35	3 NT	S 8		50	-97,0	97,0
7	53	57	3 NT	S 8		50	-97,0	97,0
20	34	94	3 NT	S 8		50	-97,0	97,0
34	77	4	3 NT	S 8		50	-97,0	97,0
8	83	59	3 NT	S 8		50	-97,0	97,0
4	37	78	3 NT	S 8		50	-97,0	97,0
1	88	84	3 NT	S 8		50	-97,0	97,0
44	21	15	3 NT	S 8		50	-97,0	97,0
2	87	27	3 NT	S 8		50	-97,0	97,0
16	74	92	3 NT	S 8		50	-97,0	97,0
9	20	28	3 NT	S 8		50	-97,0	97,0
41	62	51	3 NT	S 8		50	-97,0	97,0
18	68	6	3 NT	S 8		50	-97,0	97,0
25	89	19	3 NT	S 8		50	-97,0	97,0
22	3	5	3 NT	S 8		50	-97,0	97,0
36	43	24	3 NT	S 8		50	-97,0	97,0
32	36	79	3 NT	S 8		50	-97,0	97,0
13	11	50	3 NT	S 8		50	-97,0	97,0
24	22	54	3 NT	S 8		50	-97,0	97,0
17	90	91	3 NT	S 8		50	-97,0	97,0
21	56	49	3 NT	S 8		50	-97,0	97,0
40	14	73	3 NT	N 8		50	-97,0	97,0
45	72	67	3 NT	S 8		50	-97,0	97,0
46	12	63	3 NT	S 8		50	-97,0	97,0
14	9	46	3 NT	S 8		50	-97,0	97,0
26	31	30	3 NT	S 8		50	-97,0	97,0
12	8	38	3 NT	S 8		50	-97,0	97,0
15	71	2	3 NT	S 8		50	-97,0	97,0
28	45	29	5 Ruter	N 10		50	-97,0	97,0
27	55	25	3 NT	S 6	150	-218,0	218,0	

# IMP, 05. august 2010

Mappen: **20(52)**  
Rundenr: **18**

Vest / Alle

- ♠ A42
- ♥ K842
- ♦ AK76
- ♣ J2

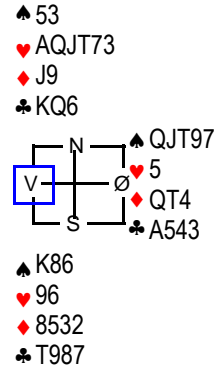

Bord	NS	ØV			NS	ØV	NS	ØV
5	13	84	2 Hjerter	Ø 6	200		464,0	-464,0
47	23	63	3 Ruter	V 8	100		395,0	-395,0
32	79	3	4 Spar	Ø 9	100		395,0	-395,0
30	35	60	4 Spar	V 9	100		395,0	-395,0
31	75	22	4 Spar	Ø 9	100		395,0	-395,0
16	32	46	4 Spar	V 9	100		395,0	-395,0
34	82	7	4 Spar	Ø 9	100		395,0	-395,0
8	78	9	4 Spar	V 9	100		395,0	-395,0
44	65	21	4 Spar	V 9	100		395,0	-395,0
13	10	66	4 Spar	Ø 9	100		395,0	-395,0
14	11	83	4 Spar	Ø 9	100		395,0	-395,0
3	27	37	4 Spar	Ø 9	100		395,0	-395,0
43	15	14	2 Spar	Ø 9		140	230,0	-230,0
25	5	19	2 Spar	Ø 9		140	230,0	-230,0
24	45	40	3 Spar	Ø 9		140	230,0	-230,0
36	76	43	2 Spar	Ø 10		170	206,0	-206,0
9	20	92	3 Spar	V 10		170	206,0	-206,0
26	89	25	2 Spar	Ø 11		200	181,0	-181,0
18	42	90	2 Hjerter D	N 6		500	-86,0	86,0
27	29	55	4 Hjerter	Ø 10		620	-186,0	186,0
17	91	38	4 Spar	Ø 10		620	-186,0	186,0
42	51	73	4 Spar	Ø 10		620	-186,0	186,0
19	85	94	4 Spar	Ø 10		620	-186,0	186,0
6	80	59	4 Spar	Ø 10		620	-186,0	186,0
35	77	69	4 Spar	Ø 10		620	-186,0	186,0
23	31	56	4 Spar	Ø 10		620	-186,0	186,0
11	71	74	4 Spar	Ø 10		620	-186,0	186,0
1	88	64	4 Spar	Ø 10		620	-186,0	186,0
7	81	57	4 Spar	Ø 10		620	-186,0	186,0
46	48	12	4 Spar	Ø 10		620	-186,0	186,0
15	68	50	4 Spar	Ø 10		620	-186,0	186,0
40	62	41	4 Spar	Ø 10		620	-186,0	186,0
22	54	58	4 Spar	Ø 10		620	-186,0	186,0
28	39	36	4 Spar	V 10		620	-186,0	186,0
2	87	53	4 Spar	Ø 10		620	-186,0	186,0
4	86	16	4 Spar	Ø 10		620	-186,0	186,0
37	24	93	4 Spar	Ø 10		620	-186,0	186,0
33	52	26	3 NT	V 10		630	-188,0	188,0
41	47	72	3 NT	V 10		630	-188,0	188,0
39	18	33	3 NT	V 11		660	-229,0	229,0
21	30	34	3 NT	V 11		660	-229,0	229,0
38	17	61	3 NT	V 11		660	-229,0	229,0
10	28	8	3 NT	V 11		660	-229,0	229,0
20	6	49	3 NT	V 11		660	-229,0	229,0
29	4	70	3 NT	V 11		660	-229,0	229,0
12	2	44	3 Hjerter D	N 6		800	-364,0	364,0
45	67	1	3 Hjerter D	N 5		1100	-544,0	544,0

# SPILLSTENSILER

Mappen: **21(53)**  
Rundenr: **18**

Nord / N/S

♠ 92  
♥ 82  
♦ KJ32  
♣ AT874

♠ QJ764

♥ 94

♦ QT98

♣ Q3

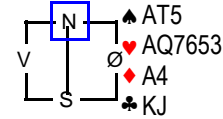

♠ K83

♥ KJT

♦ 765

♣ 9652

Bord	NS	ØV		NS	ØV	NS	ØV
32	79	3	6 Hjerter	Ø 9	150	400,0	-400,0
1	88	64	3 NT	V 7	100	373,0	-373,0
4	86	16	3 NT	V 8	50	322,0	-322,0
10	28	8	3 NT	Ø 8	50	322,0	-322,0
12	2	44	3 NT	V 8	50	322,0	-322,0
28	39	36	4 Hjerter	Ø 9	50	322,0	-322,0
16	32	46	4 Hjerter	Ø 9	50	322,0	-322,0
43	15	14	4 Hjerter	Ø 9	50	322,0	-322,0
45	67	1	4 Hjerter	Ø 9	50	322,0	-322,0
21	30	34	4 Hjerter	Ø 9	50	322,0	-322,0
5	13	84	4 Hjerter	Ø 9	50	322,0	-322,0
44	65	21	4 Hjerter	Ø 9	50	322,0	-322,0
40	62	41	4 Hjerter	Ø 9	50	322,0	-322,0
37	24	93	5 Hjerter	Ø 10	50	322,0	-322,0
2	87	53	5 Hjerter	Ø 10	50	322,0	-322,0
34	82	7	3 Hjerter	Ø 10	170	105,0	-105,0
38	17	61	3 NT	V 9	400	-115,0	115,0
20	6	49	4 Hjerter	Ø 10	420	-145,0	145,0
25	5	19	4 Hjerter	Ø 10	420	-145,0	145,0
23	31	56	4 Hjerter	Ø 10	420	-145,0	145,0
17	91	38	4 Hjerter	V 10	420	-145,0	145,0
26	89	25	4 Hjerter	Ø 10	420	-145,0	145,0
11	71	74	4 Hjerter	Ø 10	420	-145,0	145,0
24	45	40	4 Hjerter	Ø 10	420	-145,0	145,0
41	47	72	4 Hjerter	V 10	420	-145,0	145,0
42	51	73	4 Hjerter	Ø 10	420	-145,0	145,0
14	11	83	4 Hjerter	Ø 10	420	-145,0	145,0
7	81	57	4 Hjerter	Ø 10	420	-145,0	145,0
18	42	90	4 Hjerter	Ø 10	420	-145,0	145,0
46	48	12	4 Hjerter	Ø 10	420	-145,0	145,0
39	18	33	4 Hjerter	Ø 10	420	-145,0	145,0
35	77	69	4 Hjerter	Ø 10	420	-145,0	145,0
15	68	50	4 Hjerter	Ø 10	420	-145,0	145,0
3	27	37	4 Hjerter	Ø 10	420	-145,0	145,0
13	10	66	4 Hjerter	Ø 10	420	-145,0	145,0
33	52	26	4 Hjerter	Ø 10	420	-145,0	145,0
31	75	22	4 Hjerter	Ø 10	420	-145,0	145,0
6	80	59	3 NT	Ø 11	460	-191,0	191,0
30	35	60	3 NT	V 11	460	-191,0	191,0
8	78	9	4 Hjerter	Ø 11	450	-191,0	191,0
36	76	43	4 Hjerter	Ø 11	450	-191,0	191,0
19	85	94	4 Hjerter	Ø 11	450	-191,0	191,0
27	29	55	4 Hjerter	Ø 11	450	-191,0	191,0
22	54	58	4 Hjerter	Ø 11	450	-191,0	191,0
9	20	92	4 Hjerter	Ø 11	450	-191,0	191,0
29	4	70	4 Hjerter	Ø 11	450	-191,0	191,0
47	23	63	4 Hjerter D	Ø 10	590	-330,0	330,0

# IMP, 05. august 2010

Mappen: **22(54)**  
Rundenr: **18**

Øst / Ø/V

♠ A5  
♥ AKJ642  
♦ 94  
♣ 542

♠ QT97

♥ 85

♦ Q6

♣ KT973

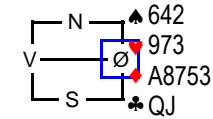

♠ KJ83

♥ QT

♦ KJT2

♣ A86

Bord	NS	ØV		NS	ØV	NS	ØV
37	24	93	1 Spar	S 9	140	152,0	-152,0
13	10	66	2 Spar	S 9	140	152,0	-152,0
14	11	83	2 Spar	N 9	140	152,0	-152,0
22	54	58	2 Spar	S 9	140	152,0	-152,0
41	47	72	2 Spar	S 9	140	152,0	-152,0
28	39	36	2 Spar	S 9	140	152,0	-152,0
15	68	50	2 Spar	N 9	140	152,0	-152,0
9	20	92	2 Spar	S 9	140	152,0	-152,0
3	27	37	2 Spar	S 9	140	152,0	-152,0
39	18	33	2 Spar	S 9	140	152,0	-152,0
34	82	7	2 Spar	S 9	140	152,0	-152,0
23	31	56	2 Spar	S 9	140	152,0	-152,0
11	71	74	3 Spar	S 9	140	152,0	-152,0
18	42	90	3 Spar	N 9	140	152,0	-152,0
16	32	46	3 Spar	S 9	140	152,0	-152,0
5	13	84	3 Spar	N 9	140	152,0	-152,0
33	52	26	3 Spar	S 9	140	152,0	-152,0
1	88	64	3 Spar	S 9	140	152,0	-152,0
47	23	63	2 Spar	S 8	110	106,0	-106,0
6	80	59	2 Spar	S 8	110	106,0	-106,0
36	76	43	2 Spar	S 8	110	106,0	-106,0
25	5	19	2 Spar	S 8	110	106,0	-106,0
26	89	25	3 Hjerter	V 8	100	106,0	-106,0
19	85	94	3 Spar	S 8	50	-69,0	69,0
30	35	60	3 Spar	S 8	50	-69,0	69,0
12	2	44	3 Spar	S 8	50	-69,0	69,0
29	4	70	3 Spar	S 8	50	-69,0	69,0
43	15	14	3 Spar	S 8	50	-69,0	69,0
42	51	73	3 Spar	S 8	50	-69,0	69,0
35	77	69	3 Spar	S 8	50	-69,0	69,0
24	45	40	3 Spar	S 8	50	-69,0	69,0
45	67	1	3 Spar	S 8	50	-69,0	69,0
31	75	22	3 Spar	S 8	50	-69,0	69,0
46	48	12	4 Spar	S 9	50	-69,0	69,0
17	91	38	4 Spar	S 9	50	-69,0	69,0
8	78	9	4 Spar	S 9	50	-69,0	69,0
7	81	57	4 Spar	S 8	100	-137,0	137,0
44	65	21	3 Hjerter	V 9	140	-185,0	185,0
38	17	61	3 Hjerter	V 9	140	-185,0	185,0
21	30	34	3 Hjerter	Ø 9	140	-185,0	185,0
10	28	8	3 Hjerter	Ø 9	140	-185,0	185,0
40	62	41	3 Hjerter	V 9	140	-185,0	185,0
2	87	53	3 Hjerter	V 9	140	-185,0	185,0
4	86	16	3 Hjerter	Ø 9	140	-185,0	185,0
20	6	49	3 Hjerter	V 9	140	-185,0	185,0
27	29	55	2 NT	N 5	150	-186,0	186,0
32	79	3	3 Hjerter D	V 9	730	-566,0	566,0

# SPILLSTENSILER

Mappenr: 23(55)

Rundenr: 19

Syd / Alle

♠ QJ63  
♥ 63  
♦ Q964  
♣ A64

♠ A52  
♥ T82  
♦ AJT7  
♣ 853

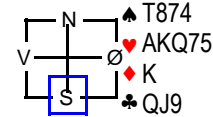

♠ K9  
♥ J94  
♦ 8532  
♣ KT72

Bord	NS	ØV			NS	ØV	NS	ØV
31	55	40	4 Spar	V 9	100		422,0	-422,0
43	73	67	4 Spar	V 9	100		422,0	-422,0
45	15	12	1 NT	V 8		120	269,0	-269,0
46	63	21	1 NT	V 9		150	227,0	-227,0
21	56	85	2 Hjerter	Ø 9		140	227,0	-227,0
10	57	32	2 Spar	V 9		140	227,0	-227,0
38	51	82	2 Spar	V 9		140	227,0	-227,0
37	24	69	1 Spar	V 10		170	202,0	-202,0
41	72	65	2 Hjerter	Ø 10		170	202,0	-202,0
40	3	47	2 Spar	V 10		170	202,0	-202,0
23	19	60	2 Spar	V 10		170	202,0	-202,0
7	84	16	2 Spar	V 10		170	202,0	-202,0
28	76	35	2 Spar	V 10		170	202,0	-202,0
12	20	11	2 Spar	V 10		170	202,0	-202,0
27	29	4	2 Spar	V 10		170	202,0	-202,0
16	6	90	2 Spar	V 10		170	202,0	-202,0
24	42	34	2 Spar	V 10		170	202,0	-202,0
20	54	68	2 Spar	V 10		170	202,0	-202,0
32	7	75	2 Spar	V 10		170	202,0	-202,0
42	93	1	2 Spar	V 10		170	202,0	-202,0
25	49	25	2 Spar	V 10		170	202,0	-202,0
18	50	94	3 Spar	V 10		170	202,0	-202,0
29	31	89	2 Spar	V 11		200	160,0	-160,0
22	91	36	2 Spar	Ø 11		200	160,0	-160,0
47	23	48	1 NT	S 4		300	66,0	-66,0
5	59	37	1 Spar	S 3		400	-30,0	30,0
8	92	78	4 Spar	V 10		620	-256,0	256,0
1	80	88	4 Spar	V 10		620	-256,0	256,0
9	28	44	4 Spar	V 10		620	-256,0	256,0
39	18	62	4 Spar	Ø 10		620	-256,0	256,0
15	5	83	4 Spar	V 10		620	-256,0	256,0
14	10	71	4 Spar	Ø 10		620	-256,0	256,0
13	74	66	4 Spar	V 10		620	-256,0	256,0
6	53	27	4 Spar	V 10		620	-256,0	256,0
30	70	52	4 Spar	V 10		620	-256,0	256,0
17	38	30	4 Spar	V 10		620	-256,0	256,0
19	58	46	4 Spar	V 10		620	-256,0	256,0
2	64	87	4 Spar	Ø 10		620	-256,0	256,0
11	8	2	4 Spar	V 10		620	-256,0	256,0
44	41	14	4 Spar	V 10		620	-256,0	256,0
4	13	9	4 Spar	V 10		620	-256,0	256,0
34	43	33	4 Spar	V 10		620	-256,0	256,0
26	39	45	4 Spar	V 10		620	-256,0	256,0
36	79	17	4 Spar	V 10		620	-256,0	256,0
3	86	81	4 Spar	V 10		620	-256,0	256,0
35	77	61	3 NT	Ø 10		630	-258,0	258,0
33	26	22	4 Spar	Ø 11		650	-285,0	285,0

# IMP, 05. august 2010

Mappenr: 24(56)

Rundenr: 19

Vest / Ingen

♠ KJ4  
♥ J64  
♦ J9432  
♣ 82

♠ A5  
♥ 7  
♦ KT85  
♣ KJT763

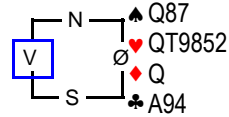

♠ T9632  
♥ AK3  
♦ A76  
♣ Q5

Bord	NS	ØV			NS	ØV	NS	ØV
17	38	30	6 Kløver	N 12	920		483,0	-483,0
38	51	82	4 Hjerter D	Ø 7	500		101,0	-101,0
45	15	12	4 Hjerter D	Ø 7	500		101,0	-101,0
10	57	32	3 NT	S 12	490		100,0	-100,0
21	56	85	3 NT	S 12	490		100,0	-100,0
40	3	47	3 NT	S 12	490		100,0	-100,0
27	29	4	3 NT	S 12	490		100,0	-100,0
28	76	35	3 NT	S 12	490		100,0	-100,0
24	42	34	3 NT	S 12	490		100,0	-100,0
46	63	21	3 NT	S 12	490		100,0	-100,0
15	5	83	3 NT	S 11	460		58,0	-58,0
4	13	9	3 NT	S 11	460		58,0	-58,0
3	86	81	3 NT	S 11	460		58,0	-58,0
11	8	2	3 NT	S 11	460		58,0	-58,0
41	72	65	3 NT	S 11	460		58,0	-58,0
9	28	44	3 NT	S 11	460		58,0	-58,0
2	64	87	3 NT	S 11	460		58,0	-58,0
30	70	52	3 NT	S 11	460		58,0	-58,0
5	59	37	3 NT	N 11	460		58,0	-58,0
37	24	69	3 NT	S 11	460		58,0	-58,0
20	54	68	3 NT	S 11	460		58,0	-58,0
25	49	25	3 NT	S 11	460		58,0	-58,0
12	20	11	3 NT	N 10	430		14,0	-14,0
42	93	1	3 NT	S 10	430		14,0	-14,0
19	58	46	3 NT	S 10	430		14,0	-14,0
8	92	78	3 NT	S 10	430		14,0	-14,0
14	10	71	3 NT	S 10	430		14,0	-14,0
7	84	16	3 NT	S 10	430		14,0	-14,0
1	80	88	3 NT	S 10	430		14,0	-14,0
6	53	27	3 NT	S 10	430		14,0	-14,0
23	19	60	3 NT	S 10	430		14,0	-14,0
16	6	90	3 NT	S 10	430		14,0	-14,0
26	39	45	3 NT	S 10	430		14,0	-14,0
13	74	66	3 NT	S 10	430		14,0	-14,0
18	50	94	3 NT	S 10	430		14,0	-14,0
47	23	48	3 NT	S 10	430		14,0	-14,0
34	43	33	3 NT	S 10	430		14,0	-14,0
43	73	67	3 NT	S 10	430		14,0	-14,0
33	26	22	4 Spar	S 10	420		11,0	-11,0
36	79	17	4 Spar	N 10	420		11,0	-11,0
31	55	40	3 Hjerter D	Ø 7	300		-139,0	139,0
44	41	14	4 Hjerter D	Ø 8	300		-139,0	139,0
22	91	36	3 Spar	S 10	170		-261,0	261,0
39	18	62	4 Spar	S 9		50	-447,0	447,0
35	77	61	4 Spar	S 9		50	-447,0	447,0
29	31	89	4 Spar	S 9		50	-447,0	447,0
32	7	75	5 Kløver	N 10		50	-447,0	447,0

# SPILLSTENSILER

Mappen: **25(57)**  
Rundenr: **19**

Nord / ØV

- ♠ K63
- ♥ 8
- ♦ AJ972
- ♣ QJ96

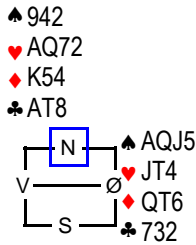

- ♠ T87
- ♥ K9653
- ♦ 83
- ♣ K54

Bord	NS	ØV		V	6	NS	ØV	NS	ØV
10	57	32	2 NT	V	6	200	178,0	-178,0	
24	42	34	4 Ruter D	V	9	200	178,0	-178,0	
25	49	25	2 Hjerter	S	10	170	141,0	-141,0	
11	8	2	2 Hjerter	S	9	140	99,0	-99,0	
34	43	33	2 Hjerter	S	9	140	99,0	-99,0	
16	6	90	2 Hjerter	S	9	140	99,0	-99,0	
38	51	82	2 Hjerter	N	9	140	99,0	-99,0	
6	53	27	3 Hjerter	S	9	140	99,0	-99,0	
32	7	75	3 Hjerter	S	9	140	99,0	-99,0	
21	56	85	3 Hjerter	S	9	140	99,0	-99,0	
8	92	78	3 Hjerter	S	9	140	99,0	-99,0	
36	79	17	3 Hjerter	S	9	140	99,0	-99,0	
31	55	40	3 Hjerter	S	9	140	99,0	-99,0	
4	13	9	3 Hjerter	N	9	140	99,0	-99,0	
40	3	47	3 Hjerter	S	9	140	99,0	-99,0	
18	50	94	2 Hjerter	S	8	110	52,0	-52,0	
1	80	88	2 Hjerter	S	8	110	52,0	-52,0	
28	76	35	2 Hjerter	N	8	110	52,0	-52,0	
20	54	68	2 Hjerter	S	8	110	52,0	-52,0	
17	38	30	2 Hjerter	S	8	110	52,0	-52,0	
7	84	16	2 Hjerter	N	8	110	52,0	-52,0	
19	58	46	2 Hjerter	S	8	110	52,0	-52,0	
45	15	12	2 Hjerter	S	8	110	52,0	-52,0	
2	64	87	2 Hjerter	N	8	110	52,0	-52,0	
14	10	71	2 Hjerter	S	8	110	52,0	-52,0	
39	18	62	2 Hjerter	S	8	110	52,0	-52,0	
46	63	21	2 Hjerter	S	8	110	52,0	-52,0	
12	20	11	3 Spar	Ø	8	100	52,0	-52,0	
41	72	65	3 Spar	Ø	8	100	52,0	-52,0	
26	39	45	3 Spar	V	8	100	52,0	-52,0	
37	24	69	4 Ruter	V	9	100	52,0	-52,0	
35	77	61	4 Spar	Ø	9	100	52,0	-52,0	
5	59	37	3 Hjerter	N	8		50	-128,0	128,0
27	29	4	3 Hjerter	S	8		50	-128,0	128,0
23	19	60	3 Hjerter	S	8		50	-128,0	128,0
30	70	52	3 Hjerter	S	8		50	-128,0	128,0
9	28	44	3 Hjerter	S	8		50	-128,0	128,0
29	31	89	3 Hjerter	S	8		50	-128,0	128,0
33	26	22	3 Spar	N	8		50	-128,0	128,0
47	23	48	4 Hjerter	S	9		50	-128,0	128,0
44	41	14	4 Hjerter	N	8		100	-189,0	189,0
43	73	67	4 Hjerter	N	8		100	-189,0	189,0
42	93	1	3 Ruter	V	10		130	-227,0	227,0
22	91	36	2 Spar	Ø	9		140	-235,0	235,0
3	86	81	3 Spar	Ø	9		140	-235,0	235,0
13	74	66	3 Spar	Ø	9		140	-235,0	235,0
15	5	83	3 Spar	Ø	9		140	-235,0	235,0

# IMP, 05. august 2010

Mappen: **26(58)**  
Rundenr: **20**

Øst / Alle

- ♠ QT62
- ♥ KQ53
- ♦ A3
- ♣ KQJ

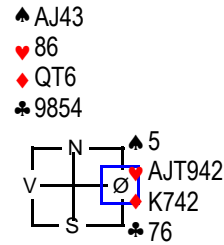

- ♠ K987
- ♥ 7
- ♦ J985
- ♣ AT32

Bord	NS	ØV		Ø	7	NS	ØV	NS	ØV
37	22	77	5 Ruter	Ø	7	400	644,0	-644,0	
29	46	69	4 Hjerter	Ø	11	650	-3,0	3,0	
33	33	52	4 Hjerter	Ø	11	650	-3,0	3,0	
47	67	23	4 Hjerter	V	11	650	-3,0	3,0	
23	55	42	4 Hjerter	Ø	11	650	-3,0	3,0	
46	14	48	4 Hjerter	Ø	11	650	-3,0	3,0	
14	94	5	4 Hjerter	Ø	11	650	-3,0	3,0	
3	27	16	4 Hjerter	Ø	11	650	-3,0	3,0	
8	81	28	4 Hjerter	V	11	650	-3,0	3,0	
9	44	8	4 Hjerter	Ø	11	650	-3,0	3,0	
4	87	78	4 Hjerter	V	11	650	-3,0	3,0	
6	53	64	4 Hjerter	Ø	11	650	-3,0	3,0	
28	89	35	4 Hjerter	Ø	11	650	-3,0	3,0	
7	37	9	4 Hjerter	Ø	11	650	-3,0	3,0	
15	84	50	4 Hjerter	V	11	650	-3,0	3,0	
35	82	43	4 Hjerter	V	11	650	-3,0	3,0	
30	75	26	4 Hjerter	Ø	11	650	-3,0	3,0	
45	93	12	4 Hjerter	Ø	11	650	-3,0	3,0	
22	39	70	4 Hjerter	V	11	650	-3,0	3,0	
26	25	45	4 Hjerter	Ø	11	650	-3,0	3,0	
18	83	56	4 Hjerter	Ø	11	650	-3,0	3,0	
12	2	11	4 Hjerter	Ø	11	650	-3,0	3,0	
40	73	18	4 Hjerter	Ø	11	650	-3,0	3,0	
21	34	6	4 Hjerter	Ø	11	650	-3,0	3,0	
2	59	88	4 Hjerter	Ø	11	650	-3,0	3,0	
10	80	92	4 Hjerter	Ø	11	650	-3,0	3,0	
20	49	68	4 Hjerter	Ø	11	650	-3,0	3,0	
43	3	63	4 Hjerter	V	11	650	-3,0	3,0	
44	41	21	4 Hjerter	V	11	650	-3,0	3,0	
27	36	76	4 Hjerter	Ø	11	650	-3,0	3,0	
19	66	54	4 Hjerter	Ø	11	650	-3,0	3,0	
25	19	91	4 Hjerter	Ø	11	650	-3,0	3,0	
38	1	72	4 Hjerter	Ø	11	650	-3,0	3,0	
41	15	7	4 Hjerter	Ø	11	650	-3,0	3,0	
32	40	29	4 Spar	Ø	11	650	-3,0	3,0	
34	4	79	5 Hjerter	V	11	650	-3,0	3,0	
11	20	10	4 Hjerter	Ø	12	680	-49,0	49,0	
13	74	38	4 Hjerter	V	12	680	-49,0	49,0	
16	71	58	4 Hjerter	V	12	680	-49,0	49,0	
31	61	31	4 Hjerter	Ø	12	680	-49,0	49,0	
42	51	17	4 Hjerter	Ø	12	680	-49,0	49,0	
17	90	30	4 Hjerter	Ø	12	680	-49,0	49,0	
1	13	32	4 Hjerter	Ø	12	680	-49,0	49,0	
39	62	47	4 Hjerter	V	12	680	-49,0	49,0	
5	57	86	4 Hjerter	V	12	680	-49,0	49,0	
24	85	60	4 Hjerter	Ø	12	680	-49,0	49,0	
36	24	65	4 Hjerter	V	12	680	-49,0	49,0	

# SPILLSTENSILER

Mappnr: 27(59)

Rundenr: 20

Syd / Ingen

- ♠ 84
- ♥ J64
- ♦ KJT97
- ♣ K85

♠ KQT5

♥ 985

♦ A85

♣ 742

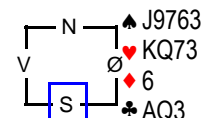

♠ A2

♥ AT2

♦ Q432

♣ JT96

Bord	NS	ØV		NS	ØV	NS	ØV
44	41	21	2 NT	S 8	120	180,0	-180,0
46	14	48	3 Hjerter	Ø 7	100	156,0	-156,0
30	75	26	3 NT	V 7	100	156,0	-156,0
4	87	78	3 Ruter D	V 8	100	156,0	-156,0
11	20	10	1 NT	S 7	90	141,0	-141,0
7	37	9	1 NT	S 7	90	141,0	-141,0
36	24	65	1 NT	S 7	90	141,0	-141,0
2	59	88	1 NT	S 7	90	141,0	-141,0
25	19	91	1 NT	S 7	90	141,0	-141,0
42	51	17	1 NT	S 7	90	141,0	-141,0
1	13	32	2 Hjerter	Ø 7	50	94,0	-94,0
28	89	35	2 Hjerter	Ø 7	50	94,0	-94,0
13	74	38	2 Hjerter	Ø 7	50	94,0	-94,0
40	73	18	2 NT	V 7	50	94,0	-94,0
35	82	43	2 Spar	Ø 7	50	94,0	-94,0
23	55	42	2 Spar	Ø 7	50	94,0	-94,0
10	80	92	2 Spar	Ø 7	50	94,0	-94,0
38	1	72	2 Spar	Ø 7	50	94,0	-94,0
16	71	58	2 Spar	Ø 7	50	94,0	-94,0
15	84	50	2 Spar	Ø 7	50	94,0	-94,0
19	66	54	2 Spar	Ø 7	50	94,0	-94,0
26	25	45	2 Spar	Ø 7	50	94,0	-94,0
37	22	77	2 Spar	V 7	50	94,0	-94,0
22	39	70	1 NT	S 6	50	-30,0	30,0
18	83	56	1 NT	S 6	50	-30,0	30,0
5	57	86	1 NT	S 6	50	-30,0	30,0
20	49	68	1 NT	S 6	50	-30,0	30,0
45	93	12	1 NT	V 7	90	-78,0	78,0
9	44	8	1 NT	Ø 7	90	-78,0	78,0
32	40	29	2 Ruter	V 8	90	-78,0	78,0
47	67	23	2 Ruter	Ø 8	90	-78,0	78,0
14	94	5	2 Hjerter	S 6	100	-91,0	91,0
24	85	60	2 NT	S 6	100	-91,0	91,0
8	81	28	2 Spar	N 6	100	-91,0	91,0
31	61	31	1 Spar	Ø 8	110	-99,0	99,0
29	46	69	2 Hjerter	Ø 8	110	-99,0	99,0
3	27	16	2 Hjerter	Ø 8	110	-99,0	99,0
6	53	64	2 Hjerter	V 8	110	-99,0	99,0
27	36	76	2 Spar	Ø 8	110	-99,0	99,0
33	33	52	1 NT	Ø 8	120	-119,0	119,0
39	62	47	2 NT	V 8	120	-119,0	119,0
12	2	11	2 Hjerter	Ø 9	140	-144,0	144,0
17	90	30	2 Hjerter	Ø 9	140	-144,0	144,0
41	15	7	1 NT	V 9	150	-148,0	148,0
34	4	79	2 Ruter D	V 8	180	-191,0	191,0
21	34	6	3 NT	S 5	200	-205,0	205,0
43	3	63	2 Hjerter D	Ø 8	470	-446,0	446,0

# IMP, 05. august 2010

Mappnr: 28(60)

Rundenr: 20

Vest / N/S

- ♠ 6
- ♥ K874
- ♦ JT62
- ♣ QJ54

♠ K5

♥ QJT63

♦ AQ9875

♣

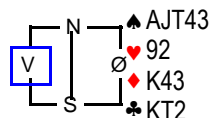

♠ Q9872

♥ A5

♦

♣ A98763

Bord	NS	ØV		NS	ØV	NS	ØV
27	36	76	4 Hjerter D	N 11	990	659,0	-659,0
21	34	6	3 Hjerter D	N 9	730	590,0	-590,0
25	19	91	4 Hjerter	N 10	620	545,0	-545,0
32	40	29	1 Spar D	Ø 5	300	394,0	-394,0
6	53	64	3 Hjerter	N 10	170	298,0	-298,0
41	15	7	3 Hjerter	N 10	170	298,0	-298,0
45	93	12	2 Hjerter	N 9	140	268,0	-268,0
42	51	17	3 Hjerter	N 9	140	268,0	-268,0
39	62	47	3 Hjerter	N 9	140	268,0	-268,0
12	2	11	1 NT D	V 6	100	230,0	-230,0
3	27	16	2 Hjerter	N 8	110	230,0	-230,0
33	33	52	3 Hjerter	Ø 8	50	179,0	-179,0
31	61	31	2 Ruter	N 7	100	41,0	-41,0
29	46	69	3 Kløver	S 8	100	41,0	-41,0
36	24	65	3 NT	S 8	100	41,0	-41,0
13	74	38	3 NT	S 8	100	41,0	-41,0
44	41	21	3 NT	S 8	100	41,0	-41,0
20	49	68	3 NT	N 8	100	41,0	-41,0
30	75	26	4 Hjerter	N 9	100	41,0	-41,0
2	59	88	4 Hjerter	N 9	100	41,0	-41,0
28	89	35	4 Hjerter	N 9	100	41,0	-41,0
24	85	60	4 Hjerter	N 9	100	41,0	-41,0
35	82	43	3 NT	S 7	200	-70,0	70,0
9	44	8	4 Hjerter	N 8	200	-70,0	70,0
18	83	56	4 Hjerter	N 8	200	-70,0	70,0
5	57	86	4 Hjerter	N 8	200	-70,0	70,0
22	39	70	4 Hjerter	N 8	200	-70,0	70,0
19	66	54	4 Hjerter	N 8	200	-70,0	70,0
11	20	10	4 Hjerter	N 8	200	-70,0	70,0
10	80	92	4 Hjerter	N 8	200	-70,0	70,0
16	71	58	4 Hjerter	N 8	200	-70,0	70,0
17	90	30	4 Hjerter	N 8	200	-70,0	70,0
1	13	32	4 Hjerter	N 8	200	-70,0	70,0
4	87	78	4 Hjerter	N 8	200	-70,0	70,0
7	37	9	4 Hjerter	N 8	200	-70,0	70,0
26	25	45	3 Hjerter	N 6	300	-171,0	171,0
37	22	77	3 NT	S 6	300	-171,0	171,0
15	84	50	3 NT	N 6	300	-171,0	171,0
8	81	28	4 Hjerter	N 7	300	-171,0	171,0
46	14	48	4 Hjerter	N 6	400	-258,0	258,0
43	3	63	5 Kløver	N 7	400	-258,0	258,0
14	94	5	3 NT D	S 7	500	-343,0	343,0
23	55	42	4 Hjerter D	N 8	500	-343,0	343,0
47	67	23	4 Hjerter D	N 8	500	-343,0	343,0
40	73	18	4 Ruter D	N 8	500	-343,0	343,0
38	1	72	4 Hjerter D	N 7	800	-538,0	538,0
34	4	79	4 Hjerter R	N 8	1000	-617,0	617,0